

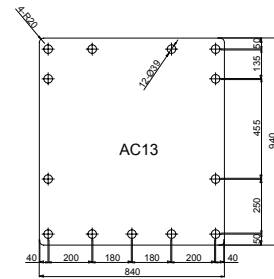

# BEILITE® EUROPE BLTB-200-5-W

HYDRAULIKHAMMER | HYRAULISCHE HAMER | MARTEAU HYDRAULIQUE | HYDRAULIC HAMMER

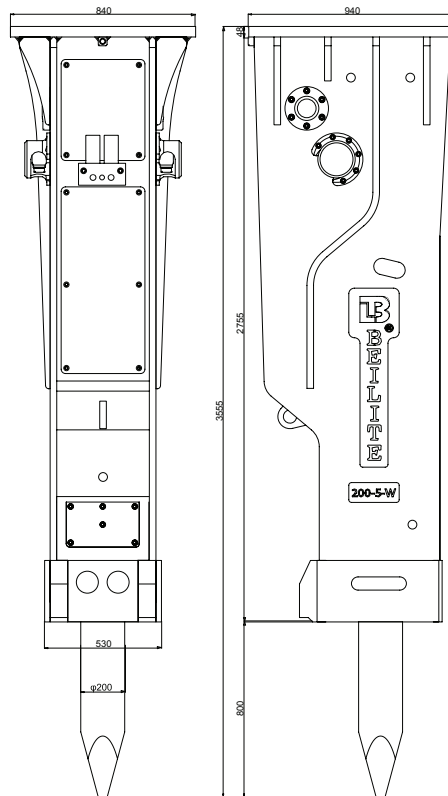
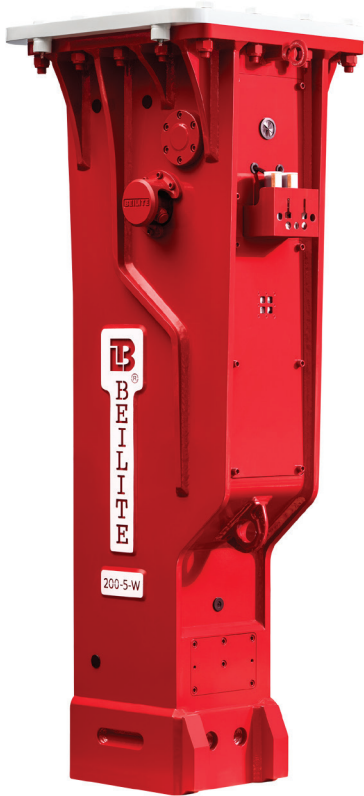

standard  
BI-B@LUBE



standard  
B@TRACK&CHECK

Deutsch | Nederlands | Français | English

<b>GESAMTGEWICHT</b>   WERKGEWICHT   <b>POIS EN ORDRE DE MARCHÉ</b>   WORKING WEIGHT 1*)	kg	5240
<b>GESAMTLÄNGE</b>   LENGTE   <b>LONGUEUR TOTALE</b>   TOTAL LENGTH 2*)	mm	3555
<b>BAGGERGRÖSSE</b>   GRAAFMACHINE KLASSE   <b>EXCAVATRICE APPLICABLE</b>   APPLICABLE EXCAVATOR	t	50-65
<b>ÖLFLUSS</b>   OLIESTROOM   <b>DÉBIT D'HUILE</b>   WORKING OIL FLOW	l/min	280-330
<b>BAGGER-EINSTELLDRUCK</b>   STEL DRUK GRAAFMACHINE   <b>PRESSION DE L'EXCAVATEUR</b>   SET PRESSURE EXCAVATOR	bar	330
<b>BETRIEBSDRUCK</b>   WERKDRUK   <b>PRESSION DE FONCTIONNEMENT</b>   OPERATING PRESSURE	bar	280-300
<b>SCHLAGFREQUENZ</b>   SLAGFREQUENTIE   <b>FRÉQUENCE D'IMPACT</b>   IMPACT RATE	bpm	100-130
<b>WERKZEUGDURCHMESSER</b>   BEITEL DIAMETER   <b>DIAMÈTRE DU BURIN</b>   CHISEL DIAMETER	mm	200
<b>WERKZEUGLÄNGE</b>   BEITEL LENGTE   <b>LONGUEUR DU BURIN</b>   CHISEL LENGTH	mm	1620
<b>SCHLAUCHANSCHLUSS</b>   SLANG AANSLUITING   <b>DIAMÈTRE DU TUYAU</b>   HOSE DIAMETER 10*)	inch	1 1/4
<b>KOLBENSPEICHERDRUCK</b>   ZUIGERACCUMULATOR DRUCK   <b>PRESSION ACCUMULATEUR PISTON</b>   N2 PRESSURE (BACK HEAD)	bar	27-30
<b>AKKUMULATORDRUCK</b>   ACCUMULATOR DRUCK   <b>PRESSION ACCUMULATEUR</b>   N2 PRESSURE (ACCUMULATOR)	bar	65-70
<b>SCHALL 85DB(A)-ENTFERNUNG</b>   GELUID 85DB(A)-AFSTAND   <b>BRUIT 85DB(A)-DISTANCE</b>   NOISE 85DB(A)-DISTANCE	m	50-55
<b>LOCHMUSTER</b>   GATENPATROON   <b>MODÈLE DE TROUS</b>   HOLE PATTERN		AC15
<b>SCHRAUBENGRÖSSE</b>   BOUTGROOTTE   <b>TAILLE DE BOULON</b>   BOLT SIZE		M36
<b>SCHMIERSYSTEM</b>   SMEERSYSTEEM   <b>SYSTÈME DE LUBRIFICATION AUTOMATIQUE</b>   AUTOMATIC GREASING SYSTEM		5*)
<b>KABELLOSER DATENTRACKER</b>   DRAADLOZE GEGEVENSTRACKER   <b>TRACEURS DE DONNÉES SANS FIL</b>   WIRELESS DATA TRACKER		standard

1\*) ARBEITSGEWICHT kann je nach Ausführung abweichen | GEWICHT Kan afhankelijk van de uitvoering afwijken | POIDS Peut varier selon l'exécution | WORKING WEIGHT may vary depending on the version 2\*) GESAMTLÄNGE mit Meißel | TOTAALLENGTE met beitel | LONGUEUR TOTALE avec burin | TOTAL LENGTH with Chisel

3\*) MINI B@LUBE SCHMIERSYSTEM optional | MINI B@LUBE SMEERSYSTEEM optioneel | MINI B@LUBE SYSTÈME DE LUBRIFICATION AUTOMATIQUE optionnel | MINI B@LUBE AUTOMATIC GREASING SYSTEM optional

4\*) B@LUBE SCHMIERSYSTEM standard | B@LUBE SMEERSYSTEEM standaard | B@LUBE SYSTÈME DE LUBRIFICATION AUTOMATIQUE standard | B@LUBE AUTOMATIC GREASING SYSTEM standard

5\*) BI-B@LUBE SCHMIERSYSTEM standard | BI-B@LUBE SMEERSYSTEEM standaard | BI-B@LUBE SYSTÈME DE LUBRIFICATION AUTOMATIQUE standard | BI-B@LUBE AUTOMATIC GREASING SYSTEM standard



ACDE® Europe

Netherlands ☎ +31 316 267291

Niederlande ☎ +31 6 53150283

Switzerland ☎ +41 625880164

Schweiz ☎ +41 793649583

✉ info@acde-europe.com

🌐 www.acde-europe.com



ADVANCED CONSTRUCTION & DEMOLITION EQUIPMENT

