

S150-D demolition and sorting grab			
order No.	position	qty	description
S150D.001	001	1	Welded main frame construction S150-D
S150D.002	002	1	Shell left (short lever) S150-D
S150D.003	003	1	Shell right (long lever) S150-D
S150D.004	004	1	Welded rotator frame construction S150-D
S150D.005	005	1	Welded linkage construction S150-D
S150D.006	006	1	Hydraulic cylinder S150-D
S150D.007	007	1	Baseplate head S150-D
S150D.008	008	1	Slewing ring S150-D
S150D.009	009	2	Main hinge pin Ø30mm S150-D
S150D.010	010	1	Linkage axis Ø40mm (top/long) S150-D
S150D.011	011	1	Linkage axis Ø30mm (under/short) S150-D
S150D.012	012	3	Disk spring S150-D
S150D.013	013	3	Castellated nut M20 S150-D
S150D.014	014	3	Spline pin 6,3mm x 63 secure on M20) S150-D
S150D.015	015	1 set	Locker set linkage axis top/long (2 pcs) S150-D
S150D.016	016	1 set	Bolt set for locker set linkage axis top/long S150-D
S150D.017	017	2	Bearings right shell (long hinge) S150-D
S150D.018	018	2	Barings left shell (short hinge) S150-D
S150D.019	019	4	Bearings main frame S150-D
S150D.020	020	2	Locker-u S150-D
S150D.021	021	1 set	Lubrication nipple 1/8"G (11 pcs) S150-D
S150D.022	022	2	Shell hinge short S150-D
S150D.023	023	2	Shell hinge long S150-D
S150D.024	024	4	Shell hinge support S150-D
S150D.025	025	1 set	Fixed blade S150-D
S150D.028	028	1 set	Hose kit main frame (2 pcs) S150-D
S150D.029	029	1	V-ring (central ring) S150-D
S150D.030	030	1 set	Bolt set slewing ring S150-D
S150D.031	031	1 set	Bolt set base plate (4 pcs) S150-D
S150D.032	032	2	Connection block base plate S150-D
S150D.033	033	1 set	O-ring connection block base plate (2 pcs) S150-D
S150D.034	034	1 set	Bolt set C.O.D. connection block S150-D
S150D.035	035	1 set	O-ring C.O.D. (4 pcs) S150-D
S150D.036	036	1	C.O.D. complete S150-D
S150D.037	037	1 set	Bolt set C.O.D. (2 pcs) S150-D
S150D.038	038	1 set	Nipples base plate (4 pcs) S150-D
S150D.039	039	1	Bearing gear S150-D
S150D.040	040	1	Gear S150-D
S150D.041	041	1	Hydro motor S150-D
S150D.042	042	1 set	Seal kit hydro motor S150-D
S150D.043	043	1 set	Bolt set hydro motor S150-D
S150D.056	056	1	Slewing ring seal S150-D
S150D.PBS	PBS	1 set	Maintenance kit pivot points (incl. all axes, bushes etc.) S150-D

S150-D  
standard hole pattern

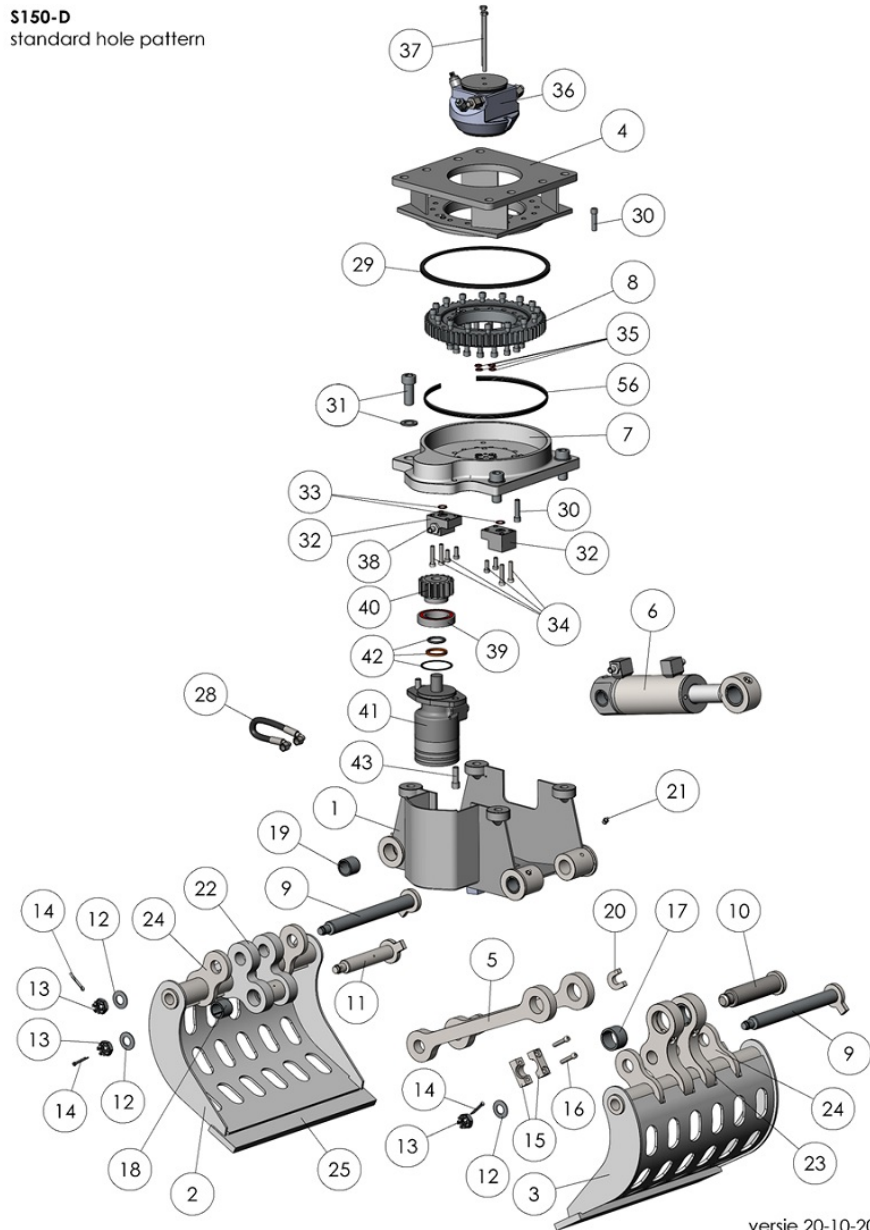

S150-D cylinder			
order No.	position	qty	description
S150D.101	101	1	Cylinder housing S150-D
S150D.102	102	1	Piston rod S150-D
S150D.103	103	1	Cylinder nut S150-D
S150D.104	104	1	Piston rod S150-D
S150D.105	105	2	Bearing cylinder housing S150-D
S150D.106	106	1	Bearing cylinder nut S150-D
S150D.107	107	1 set	Cylinder seal kit S150-D
S150D.108	108	1	Secure bolt M8x12 S150-D
S150D.109	109	1	Secure bolt M6x6 S150-D
S150D.110	110	1 set	Cylinder nipple set (2 pcs) S150-D
S150D.111	111	1	Bearing cilinder piston S150-D

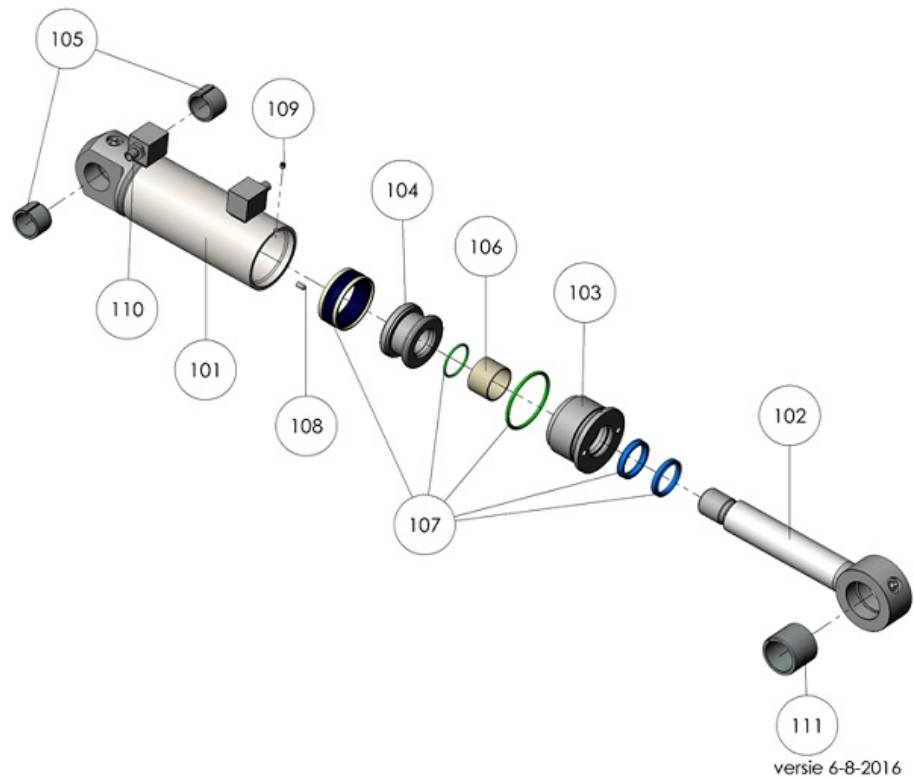

S150-D central oil distributor (C.O.D.)			
order No.	position	qty	description
S150D.201	201	1	C.O.D. housing S150-D
S150D.202	202	1	C.O.D. rotor Ø60 mm S150-D
S150D.203	203	1	C.O.D. cover S150-D
S150D.204	204	1 set	Bolt set C.O.D. (2 pcs) S150-D
S150D.205	205	1	Pressure relief valve (cross over) S150-D
S150D.206	206	1 set	Connection nipples C.O.D. housing (4 pcs) S150-D
S150D.207	207	1 set	Seal kit C.O.D. S150-D

