

S450-D demolition and sorting grab			
order No.	position	qty	description
S450D.001	001	1	Welded main frame construction S450-D
S450D.002	002	1	Shell left (short lever) S450-D
S450D.003	003	1	Shell right (long lever) S450-D
S450D.004	004	1	Welded rotator frame construction S450-D
S450D.005	005	1	Welded linkage construction S450-D
S450D.006	006	1	Hydraulic cylinder S450-D
S450D.007	007	1	Baseplate head S450-D
S450D.008	008	1	Slewing ring S450-D
S450D.009	009	2	Main hinge pin Ø45mm S450-D
S450D.010	010	1	Linkage axis Ø50mm (top/long) S450-D
S450D.011	011	1	Linkage axis Ø40mm (under/short) S450-D
S450D.012	012	3	Disk spring S450-D
S450D.013	013	3	Castellated nut M30 S450-D
S450D.014	014	3	Spline pin 6,3mm x 63 secure on M30 S450-D
S450D.015	015	1 set	Locker set linkage axis top/long (2 pcs) S450-D
S450D.016	016	1 set	Bolt set for locker set linkage axis top/long S450-D
S450D.017	017	2	Bearings right shell (long hinge) S450-D
S450D.018	018	2	Barings left shell (short hinge) S450-D
S450D.019	019	4	Bearings main frame S450-D
S450D.020	020	2	Locker-u S450-D
S450D.021	021	1 set	Lubrication nipple 1/8"G (11 pcs) S450-D
S450D.022	022	2	Shell hinge short S450-D
S450D.023	023	2	Shell hinge long S450-D
S450D.024	024	4	Shell hinge support S450-D
S450D.025	025	2	Fixed blade S450-D
S450D.026	026	1 set	Exchangeable wear blades (2 pcs) S450-D
S450D.027	027	1 set	Bolt set exchangeable wear blades (for 2 blades) S450-D
S450D.028	028	1 set	Hose kit main frame (2 pcs) S450-D
S450D.029	029	1	V-ring (central ring) S450-D
S450D.030	030	1 set	Bolt set slewing ring S450-D
S450D.031	031	1 set	Bolt set gear cover S450-D
S450D.032	032	1	Cover hydraulic motor S450-D
S450D.033	033	1 set	Bolt set hydraulic motor S450-D
S450D.034	034	1	Cover gear S450-D
S450D.035	035	1 set	O-ring to C.O.D. (4 pieces) S450-D
S450D.036	036	1	C.O.D. complete S450-D
S450D.037	037	1 set	Bolt set C.O.D. (2 pcs) S450-D
S450D.038	038	1 set	Baseplate nipples (4 pcs) S450-D
S450D.039	039	1	Bearing gear S450-D
S450D.040	040	1	Gear S450-D
S450D.041	041	1	Hydro motor S450-D
S450D.042	042	1 set	Seal kit hydro motor S450-D
S450D.043	043	1 set	Bolt set hydromotor S450-D
S450D.056	056	1	Slewing ring seal S450-D
S450D.PBS	PBS	1 set	Maintenance kit pivot points (incl. all axes, bushes etc.) S450-D

S450-D
standard hole pattern

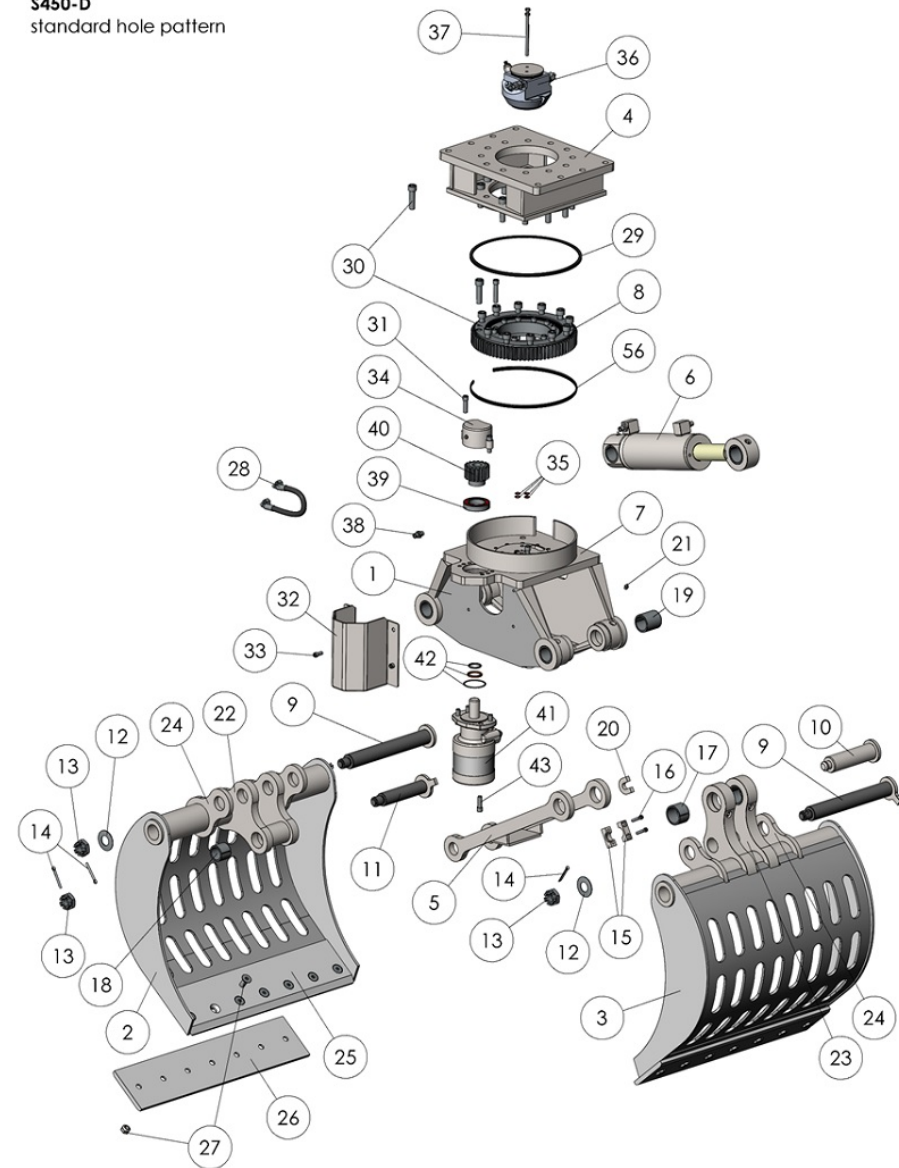

S450-D cylinder			
order No.	position	qty	description
S450D.101	101	1	Cylinder housing S450-D
S450D.102	102	1	Piston rod S450-D
S450D.103	103	1	Cylinder nut S450-D
S450D.104	104	1	Piston rod S450-D
S450D.105	105	2	Bearing cylinder housing S450-D
S450D.106	106	1	Bearing cylinder nut S450-D
S450D.107	107	1 set	Cylinder seal kit S450-D
S450D.108	108	1	Secure bolt M8x12 S450-D
S450D.109	109	1	Secure bolt M6x6 S450-D
S450D.110	110	1 set	Cylinder nipple set (2 pcs) S450-D
S450D.111	111	1	Bearing cilinder piston S450-D

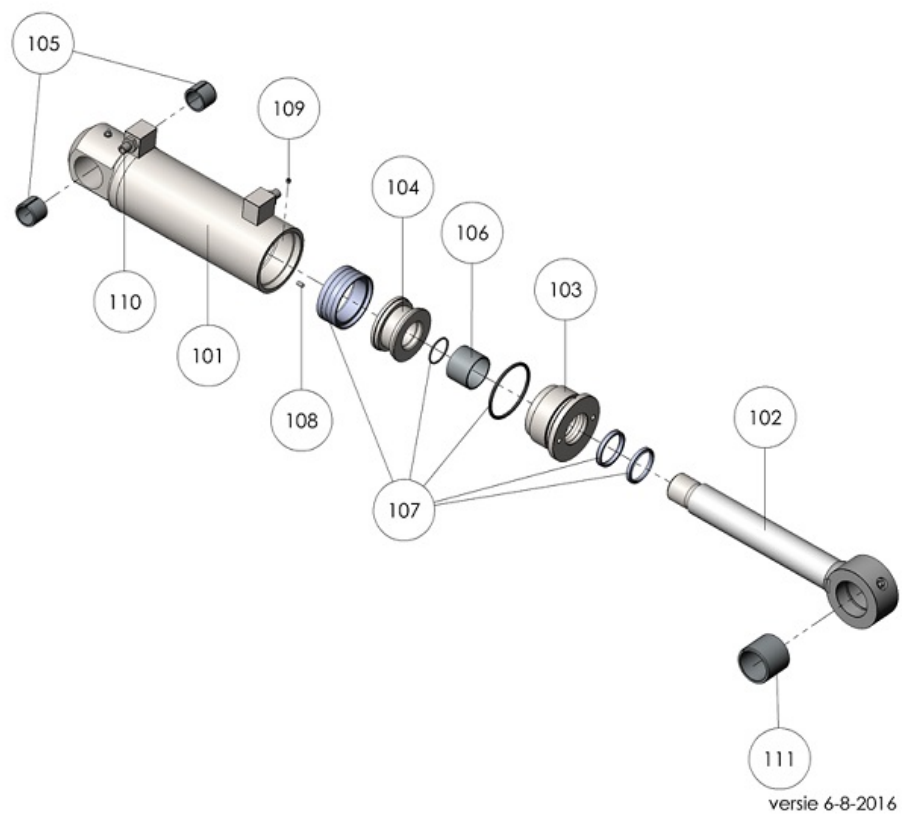

S450-D central oil distributor (C.O.D.)			
order No.	position	qty	description
S450D.201	201	1	C.O.D. housing S450-D
S450D.202	202	1	C.O.D. rotor Ø60 mm S450-D
S450D.203	203	1	C.O.D. cover S450-D
S450D.204	204	1 set	Bolt set C.O.D. (2 pcs) S450-D
S450D.205	205	1	Pressure relief valve (cross over) S450-D
S450D.206	206	1 set	Connection nipples C.O.D. housing (4 pcs) S450-D
S450D.207	207	1 set	Seal kit C.O.D. S450-D

