

## S502-D demolition and sorting grab

order No.	position	qty	description
S502D.001	001	1	Welded main frame construction S502-D
S502D.002	002	1	Shell left (short lever) S502-D
S502D.003	003	1	Shell right (long lever) S502-D
S502D.004	004	1	Welded rotator frame construction S502-D
S502D.005	005	1	Welded linkage construction S502-D
S502D.006	006	1	Hydraulic cylinder S502-D
S502D.007	007	4	Seal main hinge pin S502-D
S502D.008	008	1	Slewing ring S502-D
S502D.009	009	2	Main hinge pin Ø50mm S502-D
S502D.010	010	1	Linkage axis Ø60mm (top/long) S502-D
S502D.011	011	1	Linkage axis Ø50mm (under/short) S502-D
S502D.012	012	3	Disk spring S502-D
S502D.013	013	3	Castellated nut M42 S502-D
S502D.014	014	3	Spline pin 8mm x 60 secure on M42) S502-D
S502D.015	015	1	Castellated nut M48 S502-D
S502D.016	016	1	Spline pin 8mm x 70 seure on M48) S502-D
S502D.017	017	2	Bearings right shell (long hinge) S502-D
S502D.018	018	2	Bearings left shell (short hinge) S502-D
S502D.019	019	4	Bearings main frame S502-D
S502D.020	020	4	O-ring Metal Seal (Ø106mm) S502-D
S502D.021	021	4	Metal Seal (Ø106mm) S502-D
S502D.022	022	2	Shell hinge short S502-D
S502D.023	023	2	Shell hinge long S502-D
S502D.024	024	4	Shell hinge support S502-D
S502D.025	025	2	Fixes blade S502-D
S502D.026	026	1 set	Exchangeable wear blades (2 pcs) S502-D
S502D.027	027	1 set	Bolt set exchangeable wear blades (2 pcs) S502-D
S502D.028	028	1 set	Hose kit main frame (4 pcs) S502-D
S502D.029	029	1	V-ring (central ring) S502-D
S502D.030	030	1 set	Bolt set slewing ring S502-D
S502D.031	031	2	Locker-u S502-D
S502D.032	032	1	C.O.D. connector block S502-D
S502D.033	033	1 set	O-ring C.O.D. connector block (2 pcs) S502-D
S502D.034	034	1 set	Bolt set C.O.D. connector block (2 pcs) S502-D
S502D.035	035	2	Protection cover (connection nipples) S502-D
S502D.036	036	2	Main connect block (closing/open) function 3/4"G S502-D
S502D.037	037	2	Main connect nipple (closing/open function) S502-D
S502D.038	038	2	Main connect block (rotation function) 1/2"G S502-D
S502D.039	039	2	Main connect nipple (rotation function) S502-D
S502D.042	042	1 set	Seal kit hydro motor S502-D
S502D.043	043	1 set	Bolt set hydro motor S502-D
S502D.044	044	1	C.O.D complete S502-D
S502D.045	045	1 set	Bolt set C.O.D (2 pcs) S502-D
S502D.048	048	1	Gear S502-D
S502D.051	051	1 set	Lubrication nipple 1/8"G (11 pieces) S502-D
S502D.053	053	1 set	Hose kit rotator frame (2 pcs) S502-D
S502D.056	056	1	Slewing ring seal S502-D
S502D.059	059	1	Hydro motor (with square flange) S502-D
S502D.PBS	PBS	1 set	Maintenance kit pivot points (incl. all axes, bushes etc.) S502-D

## S502-D

standard hole pattern

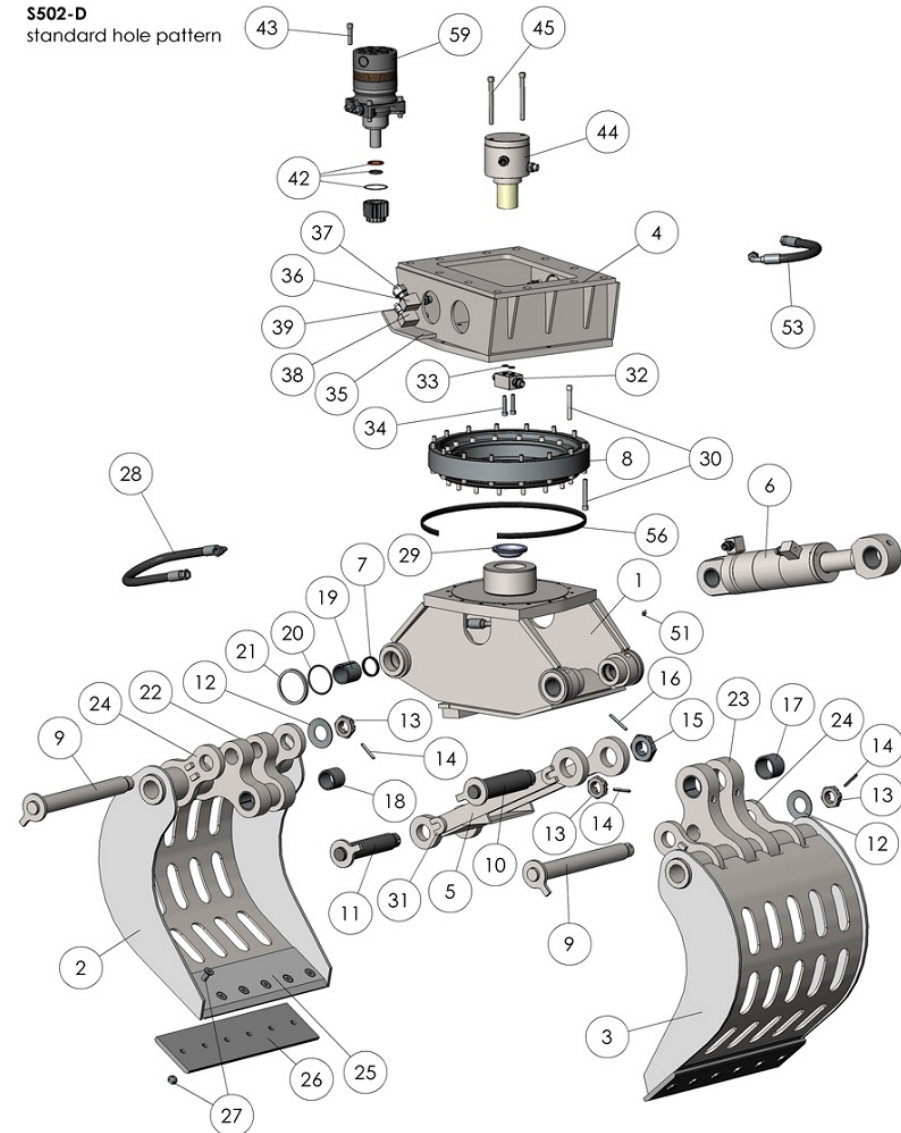

S502-D cylinder			
order No.	position	qty	description
S502D.101	101	1	Cylinder housing S502-D
S502D.102	102	1	Piston rod S502-D
S502D.103	103	1	Cylinder nut S502-D
S502D.104	104	1	Piston S502-D
S502D.105	105	1	Bearing cylinder housing S502-D
S502D.106	106	1	Bearing cylinder nut S502-D
S502D.107	107	1 set	Cylinder seal kit S502-D
S502D.108	108	1	Secure bolt M8 x12 S502-D
S502D.109	109	1	Secure bolt M6 x 6 S502-D
S502D.110	110	1 set	Cylinder nipple set (2 pcs) S502-D
S502D.111	111	1	Bearing cylinder piston S502-D

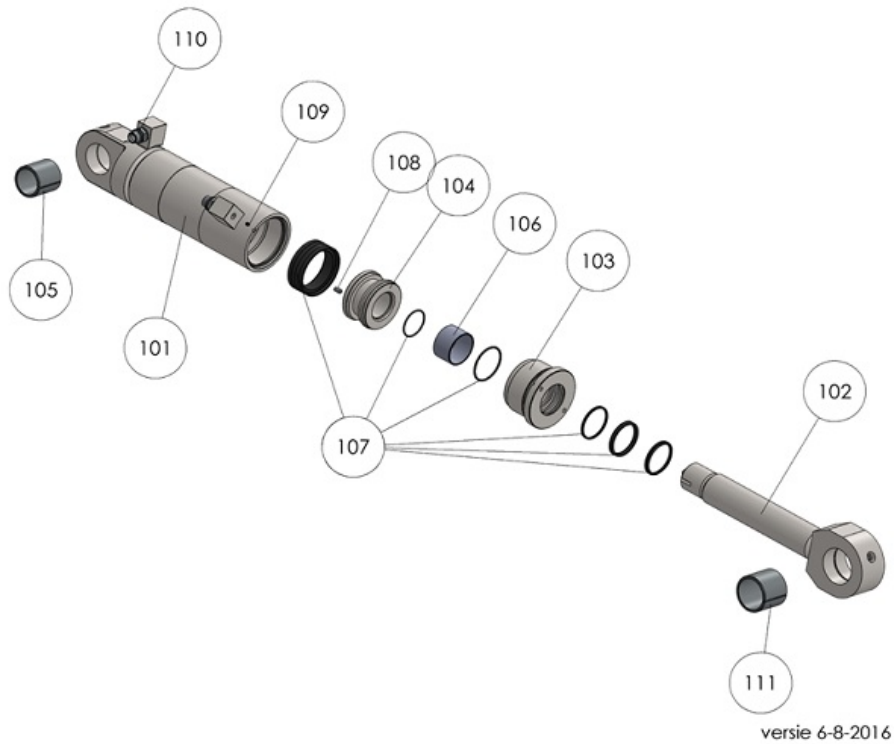

S502-D central oil distributor (C.O.D.)			
order No.	position	qty	description
S502D.201	201	1	C.O.D. housing S502-D
S502D.202	202	1	C.O.D. rotor Ø60mm S502-D
S502D.203	203	1	C.O.D. cover S502-D
S502D.204	204	1	Connection Block C.O.D. S502-D
S502D.205	205	1	Bearing S502-D
S502D.206	206	1	Seeger circlip ring S502-D
S502D.207	207	1 set	Bolt set C.O.D. connector block S502-D
S502D.208	208	1 set	Rotor seal kit C.O.D. Ø60mm S502-D
S502D.209	209	1 set	Connection nipples C.O.D. housing (2 pcs) S502-D
S502D.210	210	1 set	Connection nipples C.O.D. connection block (2 pcs) S502-D

