

S1102-D demolition and sorting grab			
order No.	position	qty	description
S1102D.001	001	1	Welded main frame construction S1102-D
S1102D.002	002	1	Shell left (short lever) S1102-D
S1102D.003	003	1	Shell right (long lever) S1102-D
S1102D.004	004	1	Welded rotator frame construction S1102-D
S1102D.005	005	1	Welded linkage construction S1102-D
S1102D.006	006	1	Hydraulic cylinder right (high nipple) S1102-D
S1102D.007	007	1	Hydraulic cylinder left (low nipple) S1102-D
S1102D.008	008	1	Slewing ring S1102-D
S1102D.009	009	2	Main hinge pin Ø60mm S1102-D
S1102D.010	010	1	Linkage axis Ø60mm (top/long) S1102-D
S1102D.011	011	1	Linkage axis Ø60mm (under/short) S1102-D
S1102D.012	012	2	Disk spring S1102-D
S1102D.013	013	2	Castellated nut M48 S1102-D
S1102D.014	014	2	Spline pin 8mm x 60 (secure on M48) S1102-D
S1102D.015	015	2	Spline pin 16mm S1102-D
S1102D.016	016	1	Locker plate Linkage axis Ø60mm (top/long) S1102-D
S1102D.017	017	2	Bearings linkage top S1102-D
S1102D.018	018	2	Bearings linkage under S1102-D
S1102D.019	019	4	Bearings main frame S1102-D
S1102D.020	020	10	O-ring metal seal (Ø120mm) S1102-D
S1102D.021	021	10	Metal seal (Ø120mm) S1102-D
S1102D.022	022	2	Shell hinge short S1102-D
S1102D.023	023	2	Shell hinge long S1102-D
S1102D.024	024	4	Shell hinge support S1102-D
S1102D.025	025	2	Fixed blade S1102-D
S1102D.026	026	1 set	Exchangeable wear blades (2 pcs) S1102-D
S1102D.027	027	1 set	Bolt set exchangeable wear blades (for 2 blades) S1102-D
S1102D.028	028	1 set	Hose kit main frame (4 pcs) S1102-D
S1102D.029	029	1	V-ring (central ring) S1102-D
S1102D.030	030	1 set	Bolt set slewing ring S1102-D
S1102D.031	031	1 set	Locker-u S1102-D
S1102D.032	032	1	Connector block C.O.D. Ø70 S1102-D
S1102D.033	033	1 set	O-ring to C.O.D. (2 pcs) S1102-D
S1102D.034	034	1 set	Bolt set connector block C.O.D. (2 pcs) S1102-D
S1102D.035	035	2	Protective cover (connection nippels) S1102-D
S1102D.036	036	2	Main connect block (closing/open function) 3/4"G S1102-D
S1102D.037	037	2	Main connect nipple (closing/open function) S1102-D
S1102D.038	038	2	Main connect block (rotation function) 1/2"G S1102-D
S1102D.039	039	2	Main connect nipple (rotation function) S1102-D
S1102D.042	042	1 set	Seal kit hydro motor (for 1 motor) S1102-D
S1102D.043	043	1set	Bolt set hydro motor (for 2 motors) S1102-D
S1102D.044	044	1	C.O.D. complete S1102-D
S1102D.045	045	1 set	Bolt set C.O.D. S1102-D
S1102D.048	048	2	Gear S1102-D
S1102D.051	051	1 set	Lubrication nipple 1/8"G (12 pieces) S1102-D
S1102D.053	053	1 set	Hose kit rotating frame (6 pcs) S1102-D
S1102D.054	054	2	O-ring metal seal (Ø106mm) S1102-D
S1102D.055	055	2	Metal seal (Ø106mm) S1102-D
S1102D.056	056	1	Slewing ring seal S1102-D
S1102D.057	057	1 set	Locker set linkage axis (under/short) S1102-D
S1102D.058	058	2	Bearings linkage axis (under/short) S1102-D
S1102D.059	059	2	Hydro motor square flange S1102-D
S1102D.PBS	PBS	1 set	Maintenance kit pivot points (incl. all axes, bushes etc.) S1102-D

S1102-D  
HM1000 hole pattern

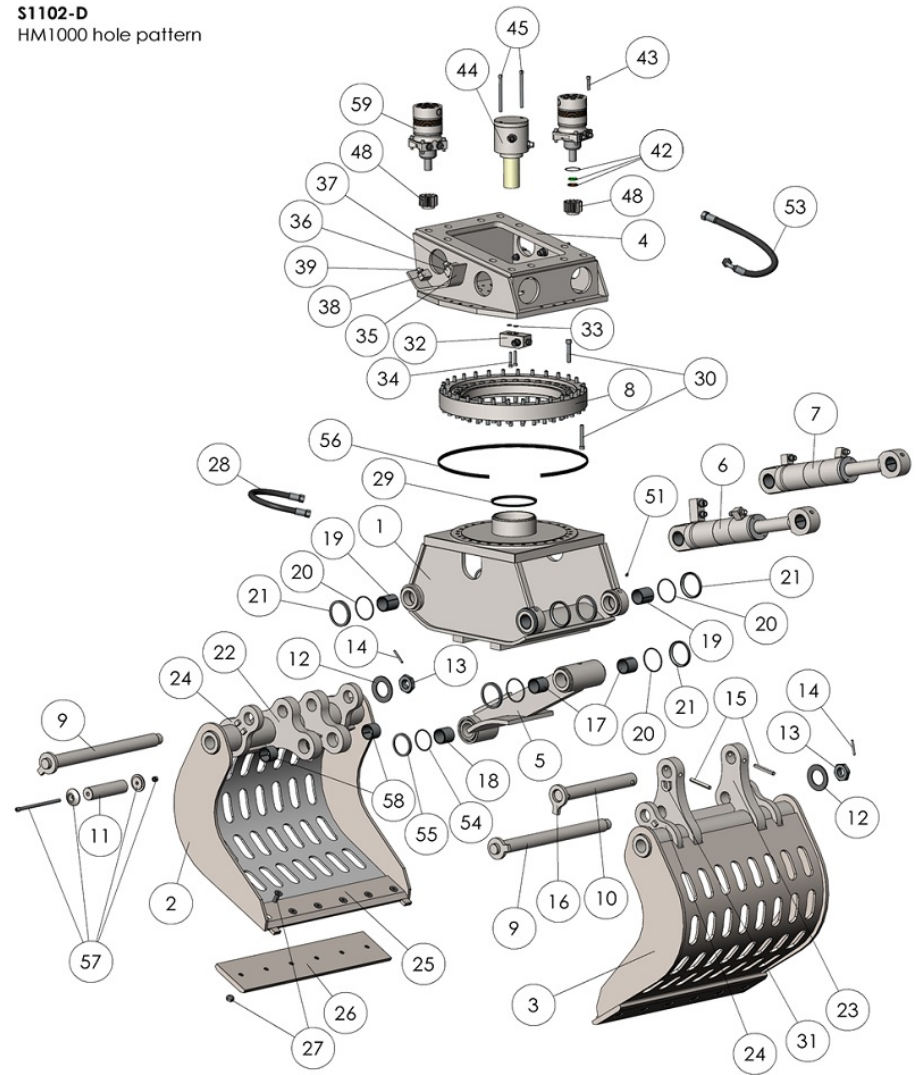

S1102-D cylinder left			
order No.	position	qty	description
S1102D.101	101	1	Cylinder housing (low connection / 2 ports) S1102-D
S1102D.102	102	1	Piston rod S1102-D
S1102D.103	103	1	Cylinder nut S1102-D
S1102D.104	104	1	Piston S1102-D
S1102D.105	105	2	Bearing cylinder housing S1102-D
S1102D.106	106	1	Bearing cylinder nut S1102-D
S1102D.107	107	1 set	Cylinder seal kit S1102-D
S1102D.108	108	1	Secure bolt M8 x12 S1102-D
S1102D.109	109	1	Secure bolt M6 x 6 S1102-D
S1102D.110	110	1 set	Cylinder nipple set (2 pcs) S1102-D

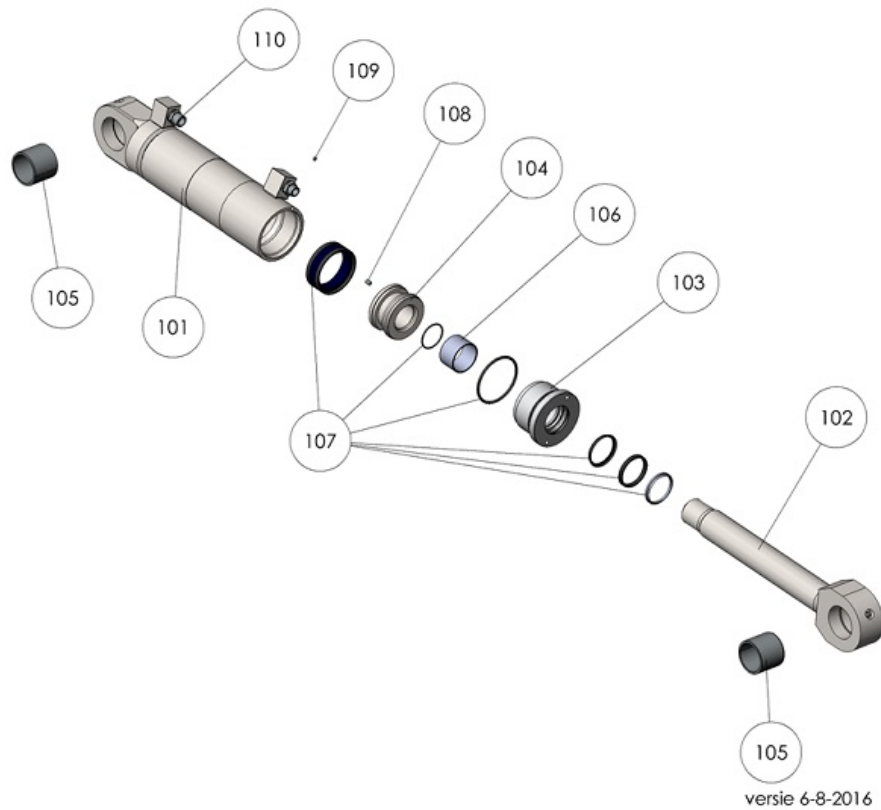

S1102-D cylinder right			
order No.	position	qty	description
S1102D.112	112	1	Cylinder housing (high connection / 4 ports) S1102-D
S1102D.102	102	1	Piston rod S1102-D
S1102D.103	103	1	Cylinder nut S1102-D
S1102D.104	104	1	Piston S1102-D
S1102D.105	105	2	Bearing cylinder housing S1102-D
S1102D.106	106	1	Bearing cylinder nut S1102-D
S1102D.107	107	1 set	Cylinder seal kit S1102-D
S1102D.108	108	1	Secure bolt M8 x12 S1102-D
S1102D.109	109	1	Secure bolt M6 x 6 S1102-D
S1102D.111	111	1 set	Cylinder nipple set (4 pcs) S1102-D

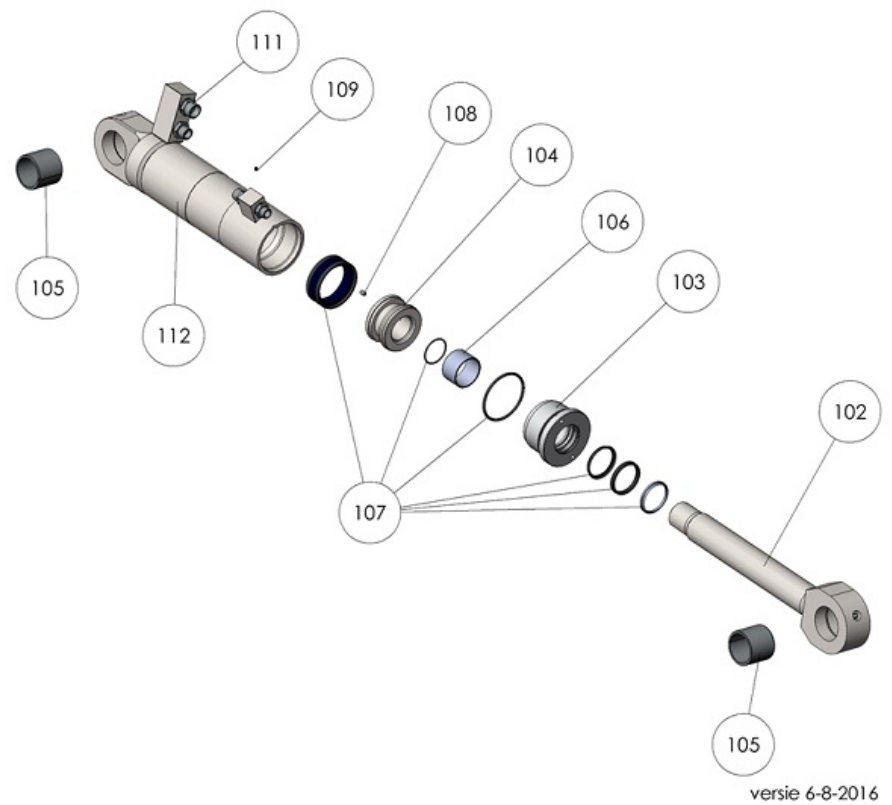

S1102-D central oil distributor (C.O.D.)			
order No.	position	qty	description
S1102D.201	201	1	C.O.D. housing S1102-D
S1102D.202	202	1	C.O.D. rotor Ø70mm S1102-D
S1102D.203	203	1	C.O.D. cover S1102-D
S1102D.204	204	1	C.O.D. connection block S1102-D
S1102D.205	205	1	Bearing S1102-D
S1102D.206	206	1	Seeger circlip ring S1102-D
S1102D.207	207	1 set	Bolt set C.O.D. connection block (2 pcs) S1102-D
S1102D.208	208	1 set	Rotor seal kit C.O.D. S1102-D
S1102D.209	209	1 set	Connection nipples C.O.D. housing (2 pcs) S1102-D
S1102D.210	210	1 set	Connection nipples C.O.D. housing (3 pcs) S1102-D

