

S603-D demolition and sorting grab

order No.	position	qty	description
S603D.001	001	1	Welded main frame construction S603-D
S603D.002	002	1	Shell left (short lever) S603-D
S603D.003	003	1	Shell right (long lever) S603-D
S603D.004	004	1	Welded rotator frame construction S603-D
S603D.005	005	1	Welded linkage construction S603-D
S603D.006	006	1	Hydraulic cylinder S603-D
S603D.007	007	4	Seal main hinge pin S603-D
S603D.008	008	1	Slewing ring S603-D
S603D.009	009	2	Main hinge pin Ø55mm S603-D
S603D.010	010	1	Linkage axis Ø65mm (top/long) S603-D
S603D.011	011	1	Linkage axis Ø55mm (under/short) S603-D
S603D.012	012	3	Disk spring S603-D
S603D.013	013	3	Castellated nut M42 S603-D
S603D.014	014	3	Spline pin 8mm x 60 secure on M42) S603-D
S603D.015	015	1	Castellated nut M48 S603-D
S603D.016	016	1	Spline pin 8mm x 70 seure on M48) S603-D
S603D.017	017	2	Bearings right shell (long hinge) S603-D
S603D.018	018	2	Bearings left shell (short hinge) S603-D
S603D.019	019	4	Bearings main frame S603-D
S603D.020	020	4	O-ring Metal Seal (Ø106mm) S603-D
S603D.021	021	4	Metal Seal (Ø106mm) S603-D
S603D.022	022	2	Shell hinge short S603-D
S603D.023	023	2	Shell hinge long S603-D
S603D.024	024	4	Shell hinge support S603-D
S603D.025	025	2	Fixes blade S603-D
S603D.026	026	1 set	Exchangeable wear blades (2 pcs) S603-D
S603D.027	027	1 set	Bolt set exchangeable wear blades (2 pcs) S603-D
S603D.028	028	1 set	Hose kit main frame (4 pcs) S603-D
S603D.029	029	1	V-ring (central ring) S603-D
S603D.030	030	1 set	Bolt set slewing ring S603-D
S603D.031	031	2	Locker-u S603-D
S603D.032	032	1	C.O.D. connector block Ø60mm S603-D
S603D.033	033	1 set	O-ring C.O.D. connector block (2 pcs) S603-D
S603D.034	034	1 set	Bolt set C.O.D. connector block (2 pcs) S603-D
S603D.035	035	2	Protection cover (connection nipples) S603-D
S603D.036	036	2	Main connect block (closing/open) function 3/4"G S603-D
S603D.037	037	2	Main connect nipple (closing/open function) S603-D
S603D.038	038	2	Main connect block (rotation function) 1/2"G S603-D
S603D.039	039	2	Main connect nipple (rotation function) S603-D
S603D.042	042	1 set	Seal kit hydro motor S603-D
S603D.043	043	1 set	Bolt set hydro motor S603-D
S603D.044	044	1	C.O.D complete S603-D
S603D.045	045	1 set	Bolt set C.O.D (2 pcs) S603-D
S603D.048	048	2	Gear S603-D
S603D.051	051	1 set	Lubrication nipple 1/8"G (11 pieces) S603-D
S603D.053	053	1 set	Hose kit rotator frame (6 pcs) S603-D
S603D.056	056	1	Slewing ring seal S603-D
S603D.059	059	2	Hydro motor (with square flange) S603-D
S603D.PBS	PBS	1 set	Maintenance kit pivot points (incl. all axes, bushes etc.) S603-D

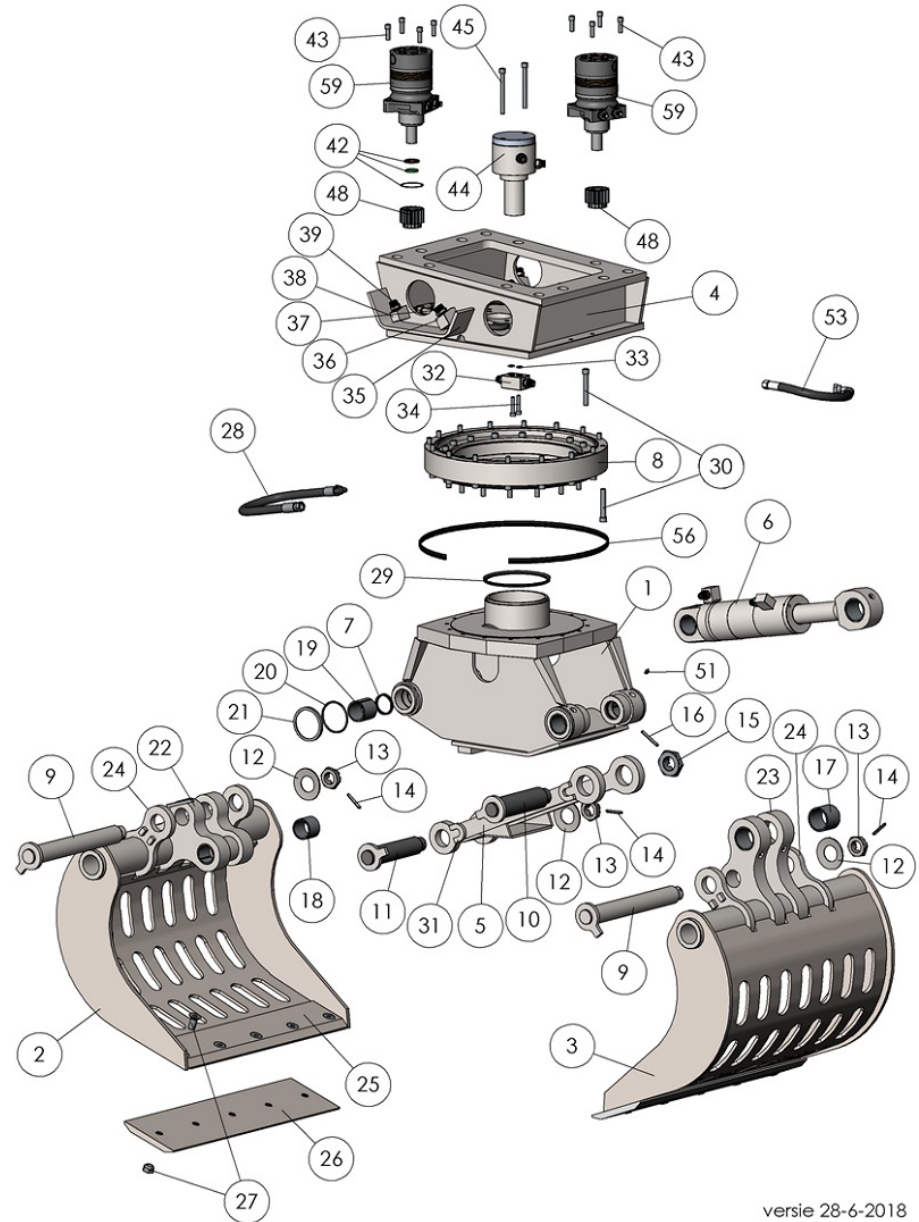

S603-D cylinder			
order No.	position	qty	description
S603D.101	101	1	Cylinder housing S603-D
S603D.102	102	1	Piston rod S603-D
S603D.103	103	1	Cylinder nut S603-D
S603D.104	104	1	Piston S603-D
S603D.105	105	1	Bearing cylinder housing S603-D
S603D.106	106	1	Bearing cylinder nut S603-D
S603D.107	107	1 set	Cylinder seal kit S603-D
S603D.108	108	1	Secure bolt M8 x12 S603-D
S603D.109	109	1	Secure bolt M6 x 6 S603-D
S603D.110	110	1 set	Cylinder nipple set (2 pcs) S603-D
S603D.111	111	1	Bearing cylinder piston S603-D

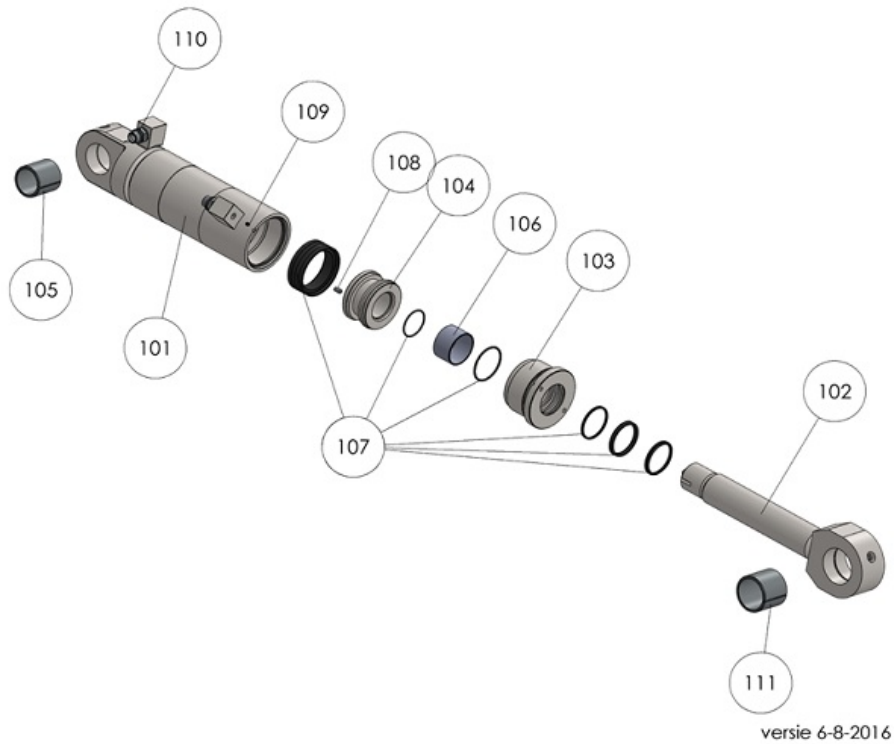

S603-D central oil distributor (C.O.D.)			
order No.	position	qty	description
S603D.201	201	1	C.O.D. housing S603-D
S603D.202	202	1	C.O.D. rotor Ø60mm S603-D
S603D.203	203	1	C.O.D. cover S603-D
S603D.204	204	1	C.O.D. connection block S603-D
S603D.205	205	1	Bearing S603-D
S603D.206	206	1	Seeger circlip ring S603-D
S603D.207	207	1 set	Bolt set C.O.D. connection block (2 pcs) S603-D
S603D.208	208	1 set	Rotor seal kit C.O.D. S603-D
S603D.209	209	1 set	Connection nipples C.O.D. housing (2 pcs) S603-D
S603D.210	210	1 set	Connection nipples connection block (2 pcs) S603-D

