



**ADVANCED CONSTRUCTION & DEMOLITION EQUIPMENT**

**ASB185G PART LIST 3/2018**

 **Hydraulische Hamer**

 **Hydrauliek Hammer**

 **Hydraulic Breaker**

 **Marteaux Hydrauliques**



**ACDE EUROPE B.V.**  
Frans Halsstraat 5  
6901 DC Zevenaar  
The Netherlands

**Phone**  
**E-mail**  
**Web**  
**Mobile**

+31 316 26 72 91  
info@acde-europe.com  
www.acde-europe.com  
+31 6 53 150 283

# ASB185G BODY

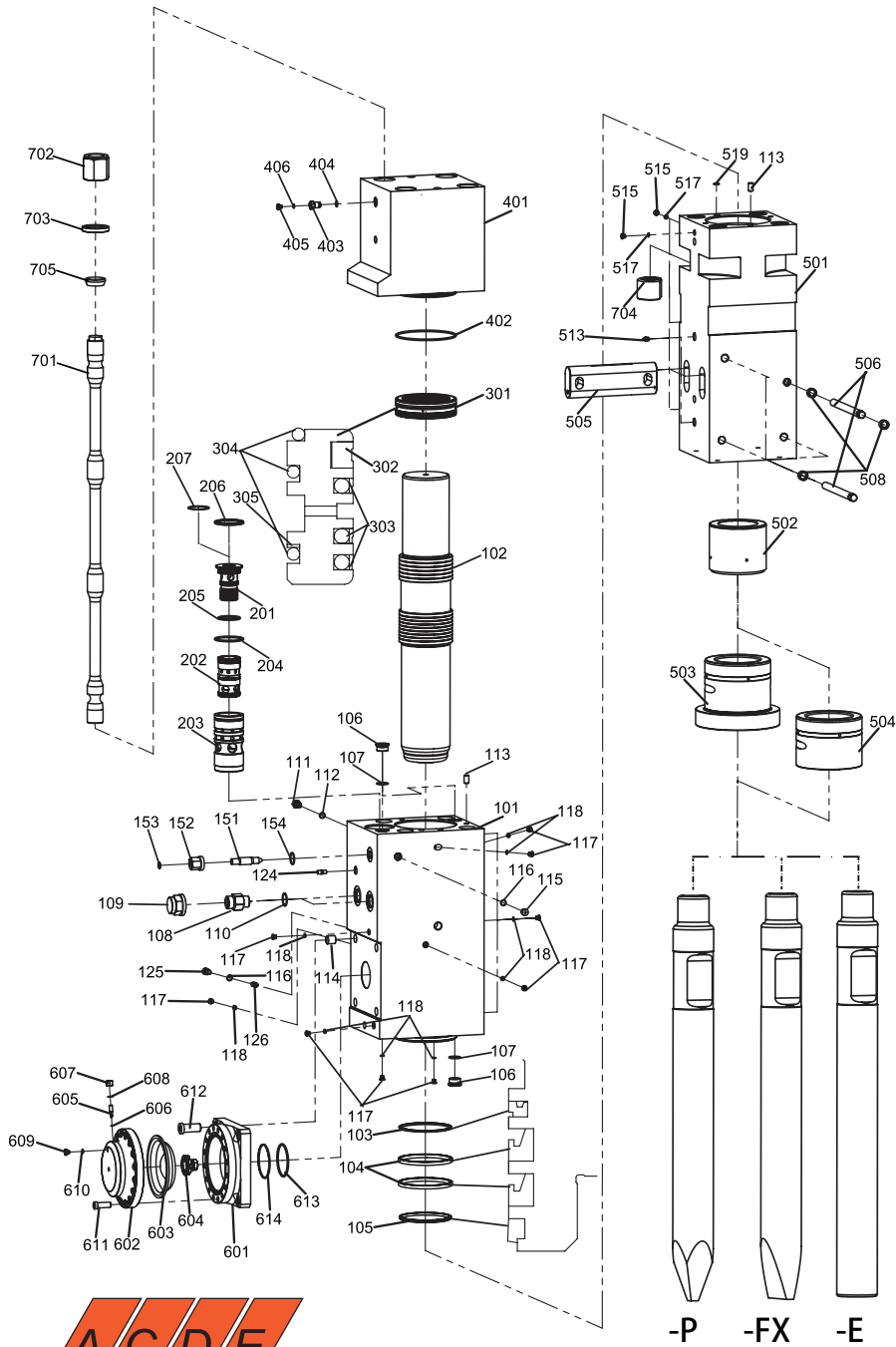

COPYRIGHT © 2018, ACDE EUROPE BV, ALL RIGHTS RESERVED

# ASB185G PART LIST

MODEL	DESCRIPTION	SPECIFICATION	QUANTITY
ASB-185G-100	CYLINDER ASSEMBLY		
ASB-185G-101	CYLINDER	350*390*861	1
ASB-185G-102	PISTON	Φ185*Φ205*Φ180*1186	1
ASB-185G-SKX-103	BUFFER RING	RUY(B) 185*205*12	1
ASB-185G-SKX-104	U-PACKING	RUS 185*205*16	2
ASB-185G-SKX-105	DUST SEAL	DUS(D) 185*198*7*9.5	1
ASB-185G-106	CYLINDER PLUG	4GN-20	2
ASB-185G-SKX-107	CYLINDER PLUG O-RING	1BP-38	2
ASB-185G-111	EXHAUST VALVE	G 1/2'	1
ASB-185G-SKX-112	EXHAUST VALVE O-RING	1BP-18	1
ASB-185G-113	GUIDE PIN	φ 18*30	4
ASB-185G-114	ACCUMULATOR BOLT	ST24*3*10	8
ASB-185G-115	CYLINDER PLUG	4GN-04L20	2
ASB-185G-SKX-116	CYLINDER PLUG O-RING	1BP-11	2
ASB-185G-SKX-118	CYLINDER O-RING	1BP-40	6
ASB-185G-119	VALVE BOLT	ST24*3*10	10
ASB-185G-121	WHITE UNION	T/B Φ50*Φ44*Φ40*30	2
ASB-185G-SKX-122	O-RING	1BP-44	4
ASB-185G-SKX-123	D-RING	φ 52* φ 58*3	2
ASB-185G-150	VALVE ADJUSTER ASSEMBLY		
ASB-185G-151	FRONT VALVE	M27*P2.0*128	1
ASB-185G-152	FRONT VALVE NUT	M27*P2.0*46	1
ASB-185G-SKX-153	FRONT VALVE O-RING	1BP-21	1
ASB-185G-SKX-154	FRONT VALVE O-RING	1BP-40	1
ASB-185G-160	VALVE ADJUSTER ASSEMBLY		
ASB-185G-161	SIDE ADJUSTER	M22*P1.5*80	1
ASB-185G-162	SIDE ADJUSTER NUT	M22*P1.5*18	1
ASB-185G-SKX-163	SIDE ADJUSTER O-RING	1BP-14	1
ASB-185G-SKX-164	SIDE ADJUSTER WHITE RING	T3P-14	1
ASB-185G-200	VALVE ASSEMBLY		
ASB-185G-201	VALVE COVER	Φ110*Φ200*Φ90*Φ84X128	1
ASB-185G-202	VALVE SLEEVE	φ 85.5* φ 84*163	1
ASB-185G-203	VALVE	φ 85.5* φ 70.7* φ 70*227	1
ASB-185G-SKX-204	VALVE COVER WHITE RING	T3P-80	1
ASB-185G-SKX-205	VALVE COVER O-RING	1BP-80	1
ASB-185G-206	VALVE BOTTOM	330X322X225X160	1
ASB-185G-207	SIDE SOCKET PLUG	4GN-06	1
ASB-185G-SKX-208	PROCESS PLUG O-RING	1BP-14	1
ASB-185G-209	BOTTOM SOCKET PLUG	130*130*45	1
ASB-185G-SKX-210	BOTTOM SOCKET PLUG O-RING	1BP-80	1
ASB-185G-214	VALVE COVER BOLT	M24*3*60	6
ASB-185G-215	VALVE BOTTOM BOLT	M24*3*70	10
ASB-185G-SKX-216	VALVE BOTTOM PROTECT RING	4BG-90	1
ASB-185G-SKX-217	VALVE BOTTOM O-RING1	1BG-90	1
ASB-185G-SKX-218	VALVE BOTTOM O-RING2	1BG-30	1
ASB-185G-SKX-219	VALVE BOTTOM O-RING3	1BG-40	2
ASB-185G-SKX-220	VALVE BOTTOM O-RING4	1BG-50	2
ASB-185G-SKX-221	VALVE BOTTOM O-RING5	1BG-60	1
ASB-185G-300	PISTON BUSH ASSEMBLY		
ASB-185G-301	PISTON BUSH	Φ230*70	1
ASB-185G-SKX-302	GAS SEAL	GS 180*9.7	1
ASB-185G-SKX-303	STEP SEAL	SS H 180*7.8	3
ASB-185G-SKX-304	O-RING	1BG-220	2
ASB-185G-SKX-305	WHITE RING	T3G-220	3

# ASB185G PART LIST

MODEL	DESCRIPTION	SPECIFICATION	QUANTITY
ASB-185G-400	BACK HEAD ASSEMBLY		
ASB-185G-401	BACK HEAD	350*390*435	1
ASB-185G-SKX-402	BACK HEAD O-RING	1BG-220	1
ASB-185G-403	CHARGING VALVE	G 1/2'	1
ASB-185G-SKX-404	CHARGING VALVE O-RING	1BP-18	1
ASB-185G-405	CHARGING VALVE COVER	M10*P1.0	1
ASB-185G-SKX-406	CHARGING VALVE COVER O-RING	1BP-12	1
ASB-185G-407	IN/OUT FLANGE	123X123X67	2
ASB-185G-SKX-408	IN/OUT FLANGE O-RING 2	1BG-85	2
ASB-185G-SKX-409	IN/OUT FLANGE O-RING 1	1BG-65	2
ASB-185G-SKX-410	IN/OUT FLANGE WHITE RING	T3G-65	2
ASB-185G-411	FLANGE UNION	1BG-24	2
ASB-185G-412	FLANGE UNION CAP	9B-24	2
ASB-185G-SKX-413	UNION O-RING	1BP-44	2
ASB-185G-414	INNER SHEX.OCKET BOLT	M20*2.5*50	8
ASB-185G-415	VALVE BOLT	ST20*2.5*12	8
ASB-185G-500	FRONT HEAD ASSEMBLY		
ASB-185G-501	FRONT HEAD	350*350*927	1
ASB-185G-502	THRUST BUSH	φ 185* φ 223*225	1
ASB-185G-503	CHISEL BUSH	φ 185* φ 250*225	1
ASB-185G-505	CHISEL PIN	120X60X350	2
ASB-185G-506	BUSHING PIN	φ 26x φ 29x335	4
ASB-185G-507-P	MOIL POINT	φ 185*1700	2
ASB-185G-507-FX	CHISEL POINT	φ 185*1700	2
ASB-185G-507-E	BLUNT POINT	φ 185*1700	2
ASB-185G-513	GREASE NIPPLE	G 1/4'	2
ASB-185G-514	RUBBER PLUG	φ 32.5* φ 26 *20( φ 26 )	5
ASB-185G-515	PROCESS PLUG	4HN-18	1
ASB-185G-SKX-517	PROCESS PLUG O-RING	1BP-16	1
ASB-185G-600	ACCUMULATOR ASSEMBLY		
ASB-185G-601	ACCUMULATOR BOTTOM	320*295*95	1
ASB-185G-602	ACCUMULATOR COVER	φ 302*117	1
ASB-185G-603	DIAPHRAGM	φ 237*40	1
ASB-185G-SKX-604	INNER VALVE ASSEMBLY	φ 75*17	1
ASB-185G-605	GAS CHARGING ADJUSTER	M12*P1.25	1
ASB-185G-SKX-606	GAS CHARGING O-RING	1BP-5	1
ASB-185G-607	GAS CHARGING CAP	M12*P1.25	1
ASB-185G-SKX-608	GAS CHARGING CAP O-RING	1BP-14	1
ASB-185G-609	ACC'COVER CAP	M10*P1.0	1
ASB-185G-SKX-610	ACC'COVER CAP O-RING	1BP-12	1
ASB-185G-611	INNER COVER HEX.SOCKET BOLT	M20*1.5*55	16
ASB-185G-612	INNER BOTTOM HEX.SOCKET BOLT	M24*3.0*70	8
ASB-185G-SKX-613	O-RING	1BP-115	1
ASB-185G-SKX-614	WHITE RING	4BP-115	1
ASB-185G-700	THROUGH BOLT ASSEMBLY		
ASB-185G-701	THROUGH BOLT	RD60X4.233X1534	4
ASB-185G-702	SCREW NUT(UPPER)	RD60X4.233X95	4
ASB-185G-703	WASHER	φ 61* φ 98*17	4
ASB-185G-704	SCREW NUT(LOWER)	RD60X4.233X75	4

# ASB185G HOUSING

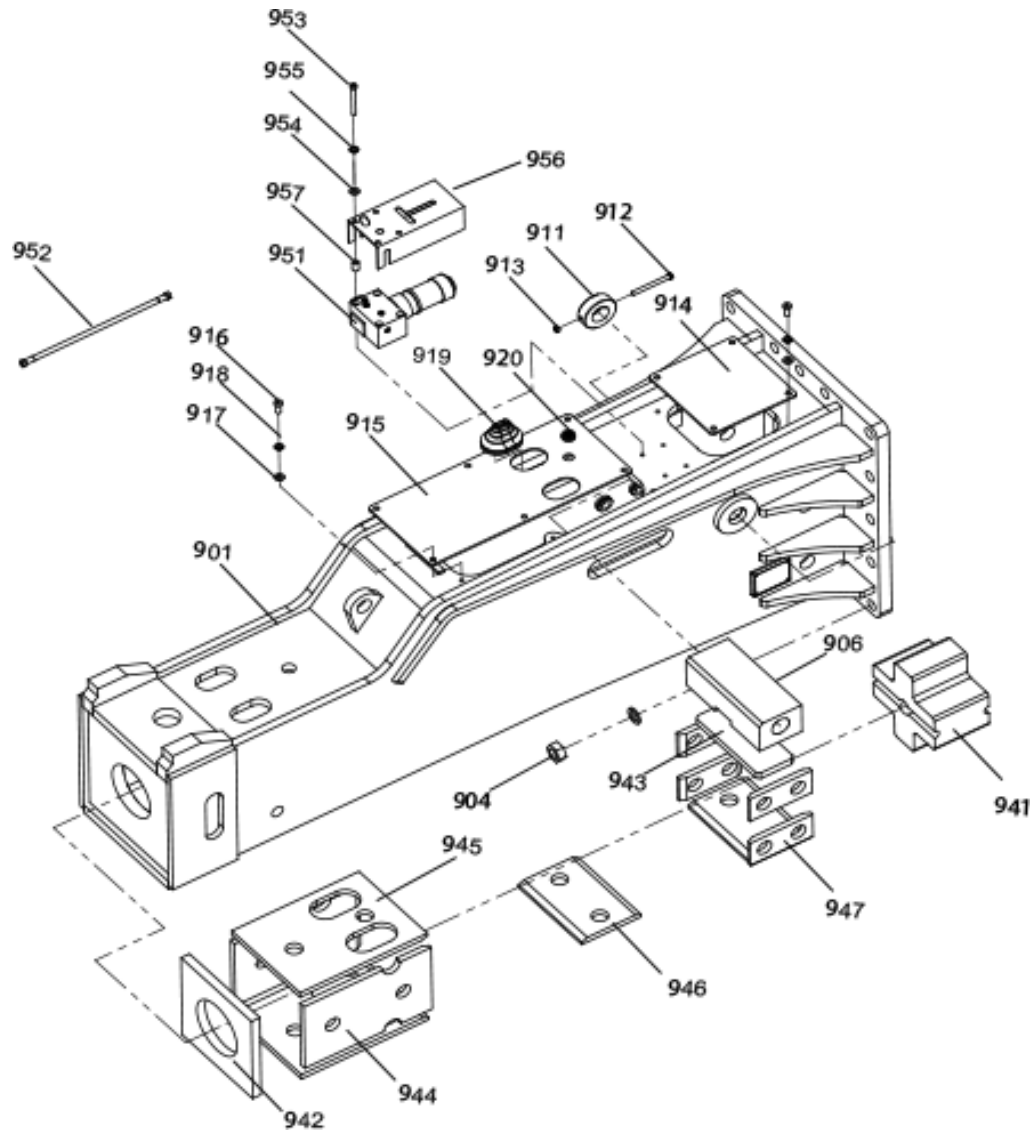



# ASB185G PART LIST

MODEL	DESCRIPTION	SPECIFICATION	QUANTITY
ASB-185G-900	FRAME ASS'Y		
ASB-185G-901	FRAME(BOX TYPE)		1
ASB-185G-906	CLAMP DAMPER	390×150×120	1
ASB-185G-910	CLAMP BOLT	φ 60×508	1
ASB-185G-911	STOP BAR	φ 60× φ 113×35	1
ASB-185G-912	HEX BOLT	M12×130	1
ASB-185G-913	HEX NUT	M12	1
ASB-185G-914	COVER PLATE-A	340×340×7	1
ASB-185G-915	COVER PLATE-B	710×340×7	1
ASB-185G-916	HEX BOLT	M14×35	10
ASB-185G-917	WASHER	14	10
ASB-185G-918	SPRING WASHER	14	10
ASB-185G-919	IN/OUT PLUG		2
ASB-185G-920	IN/OUT PLUG COVER		1
ASB-185G-940	BUFFER PLATE ASS'		
ASB-185G-941	BACK BUFFER	333×306×192	1
ASB-185G-942	LOWER DAMPER	350×350×30	1
ASB-185G-943	CLAMP DAMPER	340×130×25	1
ASB-185G-944	SIDE DAMPER	450×280×20	2
ASB-185G-945	UP&DOWN DAMPER	450×340×20	2
ASB-185G-946	SIDE DAMPER	340×250×20	2
ASB-185G-947	SIDE DAMPER	220×100×20	4
ASB-185G-950	AUTOLUB SYSTEM		
ASB-185G-951	AUTOLUB SYSTEM		1
ASB-185G-952	OIL HOSE PLUG	G1/4	1
ASB-185G-953	HEX BOLT	M12×120	4
ASB-185G-954	WASHER	12	4
ASB-185G-955	SPRING WASHER	12	4
ASB-185G-956	AUTOLUB TOOL COVER		1
ASB-185G-957	AUTOLUB TOOL NUT	φ 20× φ 13×30	4

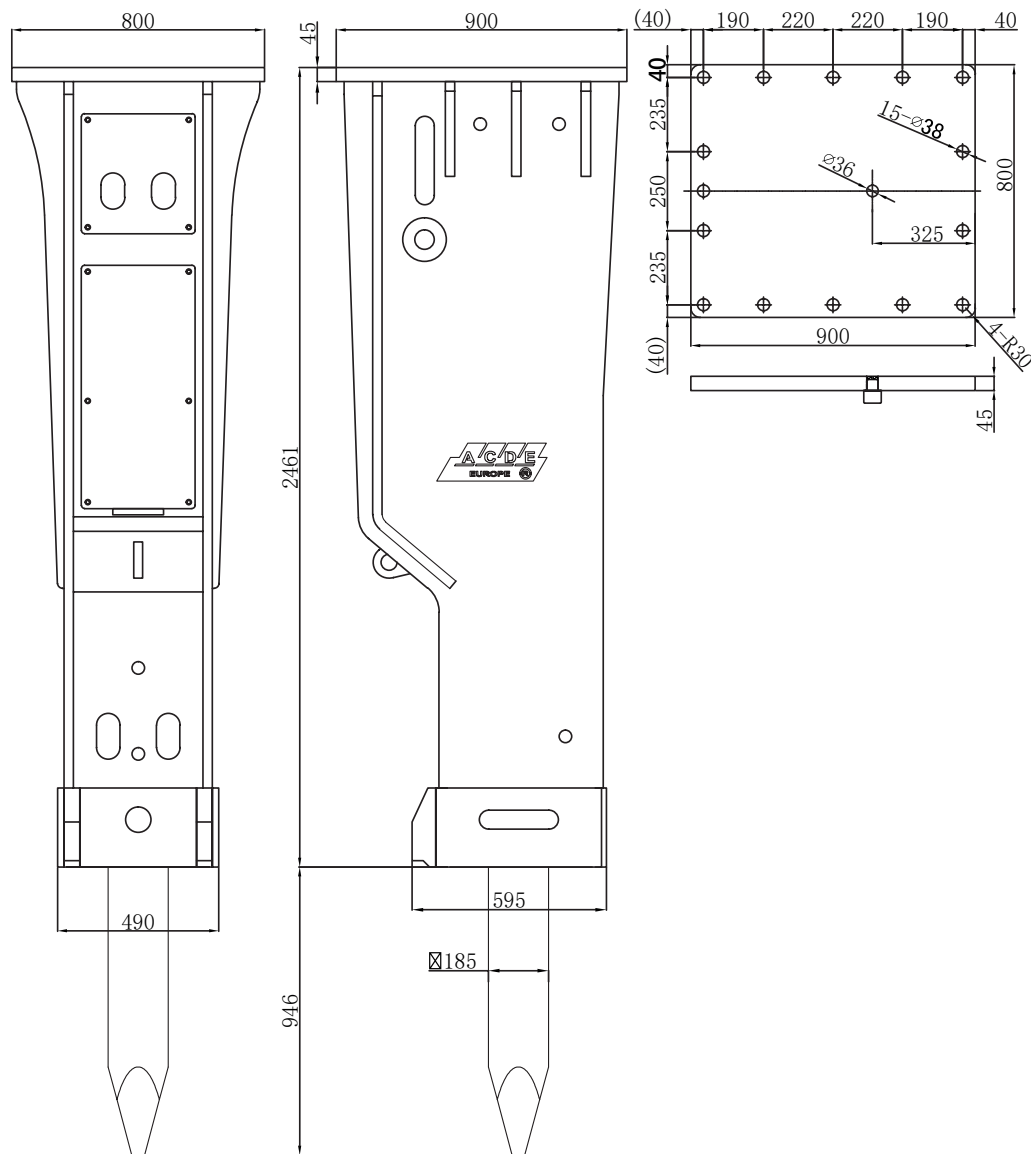

## ASB185G HOUSING MEASUREMENTS



## ACCESSOIRES

IMAGE	MODELL/TYPE	DESCRIPTION
	ACDE	N2 filling device
	ACDE	Hammer paste cartridge
	ACDE	Grease gun + cartridge

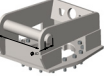
## BRACKETS

IMAGE	MODELL	DESCRIPTION
	ACDE	CW 05
	ACDE	MS 01
	ACDE	MS 03

