



ADVANCED CONSTRUCTION & DEMOLITION EQUIPMENT

ASB45 PART LIST 3/2018

 **Hydraulische Hamer**

 **Hydrauliek Hammer**

 **Hydraulic Breaker**

 **Marteaux Hydrauliques**



ACDE EUROPE B.V.
Frans Halsstraat 5
6901 DC Zevenaar
The Netherlands

Phone
E-mail
Web
Mobile

+31 316 26 72 91
info@acde-europe.com
www.acde-europe.com
+31 6 53 150 283

ASB45 BODY

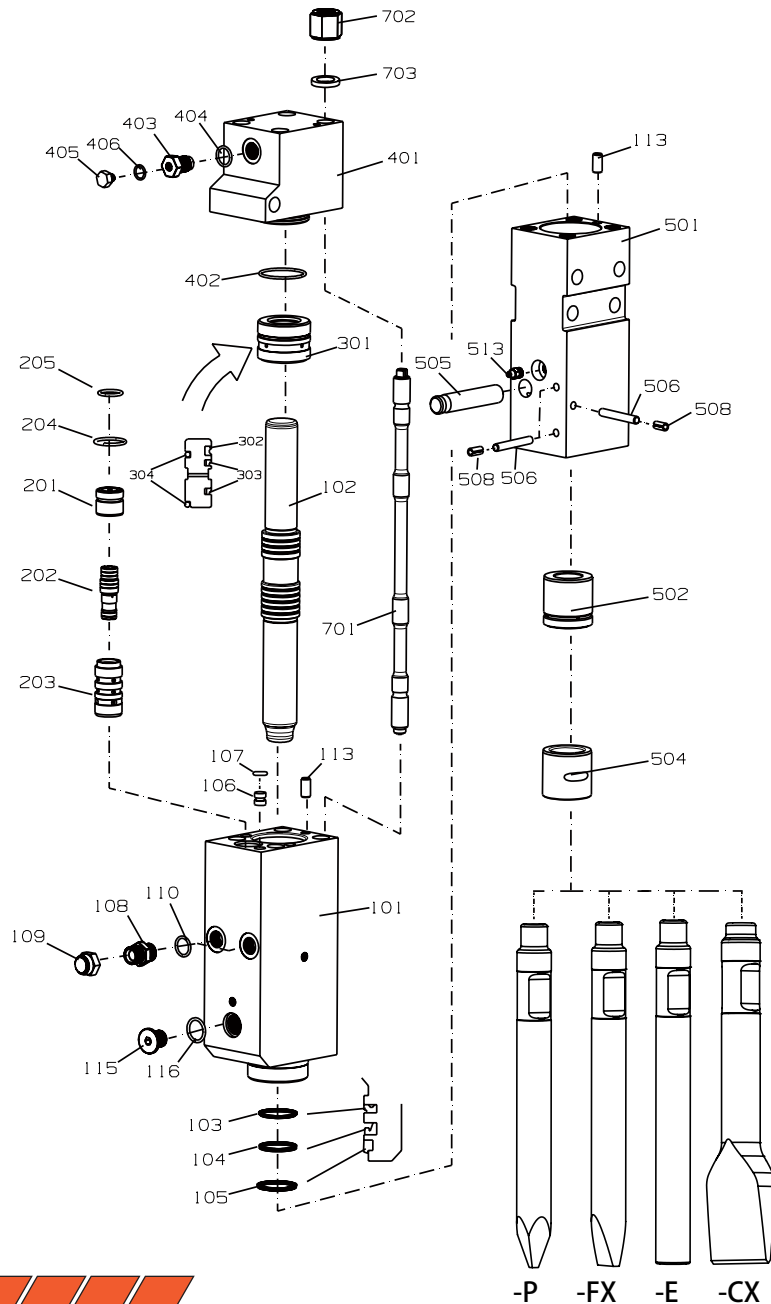

ASB45 PART LIST

MODEL	DESCRIPTION	SPECIFICATION	QUANTITY
ASB-45-100	CYLINDER ASSEMBLY		
ASB-45-101	CYLINDER	104*146*324	1
ASB-45-102	PISTON	Φ42*Φ50.7*Φ45*433	1
ASB-45-SKX-103	BUFFER RING	SRTN 45	1
ASB-45-SKX-104	U-PACKING	ISI 45*55*6	1
ASB-45-SKX-105	DUST SEAL	DSI 45*53*5*6.5	1
ASB-45-106	CYLINDER PLUG	T/P 15*16	3
ASB-45-SKX-107	O-RING	1BP-11	3
ASB-45-108	IN/OUT ADAPTER	1BG-08	2
ASB-45-109	IN/OUT ADAPTER COVER	9B-08	2
ASB-45-SKX-110	IN/OUT ADAPTER O-RING	1BP-18	2
ASB-45-113	GUIDE PIN	Φ12.5*30	2
ASB-45-115	CYLINDER PLUG(1)	4HN-24	1
ASB-45-SKX-116	CYLINDER PLUG O-RING(1)	1BP-22	1
ASB-45-117	CYLINDER PLUG(2)	4GN-04	1
ASB-45-SKX-118	CYLINDER PLUG O-RING(2)	1BP-11	1
ASB-45-200	VALVE ASSEMBLY		
ASB-45-201	VALVE COVER	Φ36*32.5	1
ASB-45-202	VALVE	Φ22*Φ24*Φ20*69	1
ASB-45-203	VALVE SLEEVE	Φ36*72.5	1
ASB-45-SKX-204	O-RING	1BP-30	1
ASB-45-SKX-205	O-RING	1BG-25	1
ASB-45-300	PISTON BUSH ASSEMBLY		
ASB-45-301	PISTON BUSH	Φ70*52	1
ASB-45-SKX-302	GAS SEAL	IKH-42	1
ASB-45-SKX-303	U-PACKING	IUIS 42*52*6	2
ASB-45-SKX-304	O-RING	1BG-65	2
ASB-45-400	BACK HEAD ASSEMBLY		
ASB-45-401	BACK HEAD	104*146*132	1
ASB-45-SKX-402	O-RING	1BG-65	1
ASB-45-403	GAS CHARGING VALVE	G 1/2'	1
ASB-45-SKX-404	O-RING	1BP-18	1
ASB-45-405	GAS CHARGING VALVE COVER	M10*P1.0	1
ASB-45-SKX-406	O-RING	1BP-12	1
ASB-45-500	FRONT HEAD ASSEMBLY		
ASB-45-501	FRONT HEAD	118*108*296	1
ASB-45-502	THRUST BUSH	φ 45* φ 65*66	1
ASB-45-504	CHISEL BUSH	φ 45* φ 65*62	1
ASB-45-505	CHISEL PIN	φ 24*117	1
ASB-45-506	BUSHING PIN	φ 10*67	3
ASB-45-507-P	MOIL POINT	φ 45*500	2
ASB-45-507-FX	CHISEL POINT	φ 45*500	2
ASB-45-507-E	BLUNT POINT	φ 45*500	2
ASB-45-507-CX	SPADE TOOL	φ 45*500	2
ASB-45-508	RUBBER PLUG	φ 10x25	3
ASB-45-513	GREASE NIPPLE	G 1/4'	1
ASB-45-700	THROUGH BOLT ASSEMBLY		
ASB-45-701	THROUGH BOLT	M22X1.5X489	4
ASB-45-702	SCREW NUT(UPPER)	M22X1.5X33	4
ASB-45-703	WASHER	φ 30* φ 23*5	4



ASB45 HOUSING

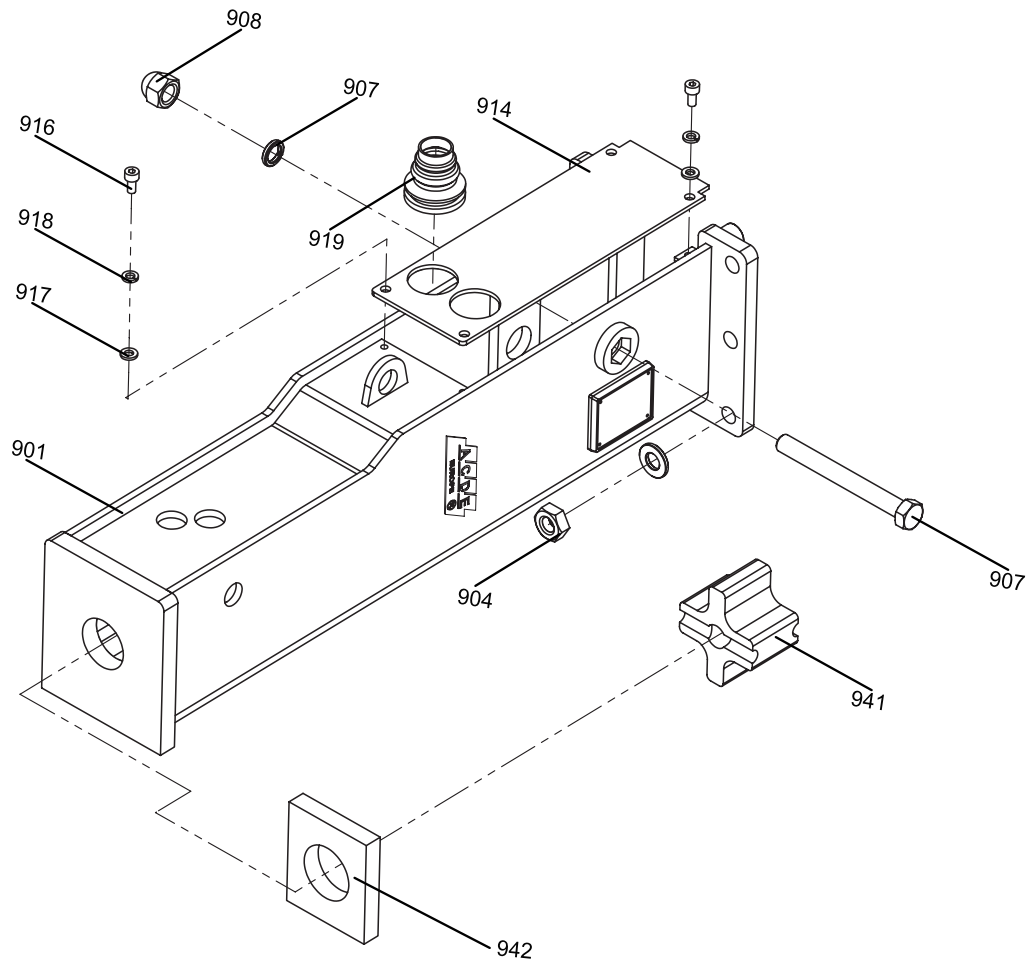

ASB45 PART LIST

NO.	DESCRIPTION	SPECIFICATION	QUANTITY
ASB45-900	FRAME ASS'Y		
ASB45-901	FRAME(BOX TYPE)		1
ASB45-902	MOUNT CAP		1
ASB45-903	M/C HEX BOLT	M16×60	6
ASB45-904	M/C HEX NUT	M16	6
ASB45-905	M/C SPRING WASHER	平垫16	12
ASB45-907	SIDE HEX BOLT	M18×1.5×166	1
ASB45-908	HEX NUT	M18×1.5	1
ASB45-909	WASHER	φ 18.2×φ27.5×4.5	1
ASB45-914	UP SIDE DAMPER	362×125×4.5	1
ASB45-916	HEX BOLT	M8×16	4
ASB45-917	WASHER	8	4
ASB45-918	SPRING WASHER	8	4
ASB45-919	IN/OUT PLUG		2
ASB45-940	BUFFER PLATE ASS'		
ASB45-941	BACK BUFFER	112×98×65	1
ASB45-942	LOWER DAMPER	118×104×20	1
ASB45-1102	PIN		2
ASB45-1103	T-BUSH		4
ASB45-1104	PIN HEX BOLT	M10×80	2
ASB45-1105	PIN HEX NUT	M10	2
ASB45-1106	STOP BAR		2

ASB45 HOUSING MEASUREMENTS

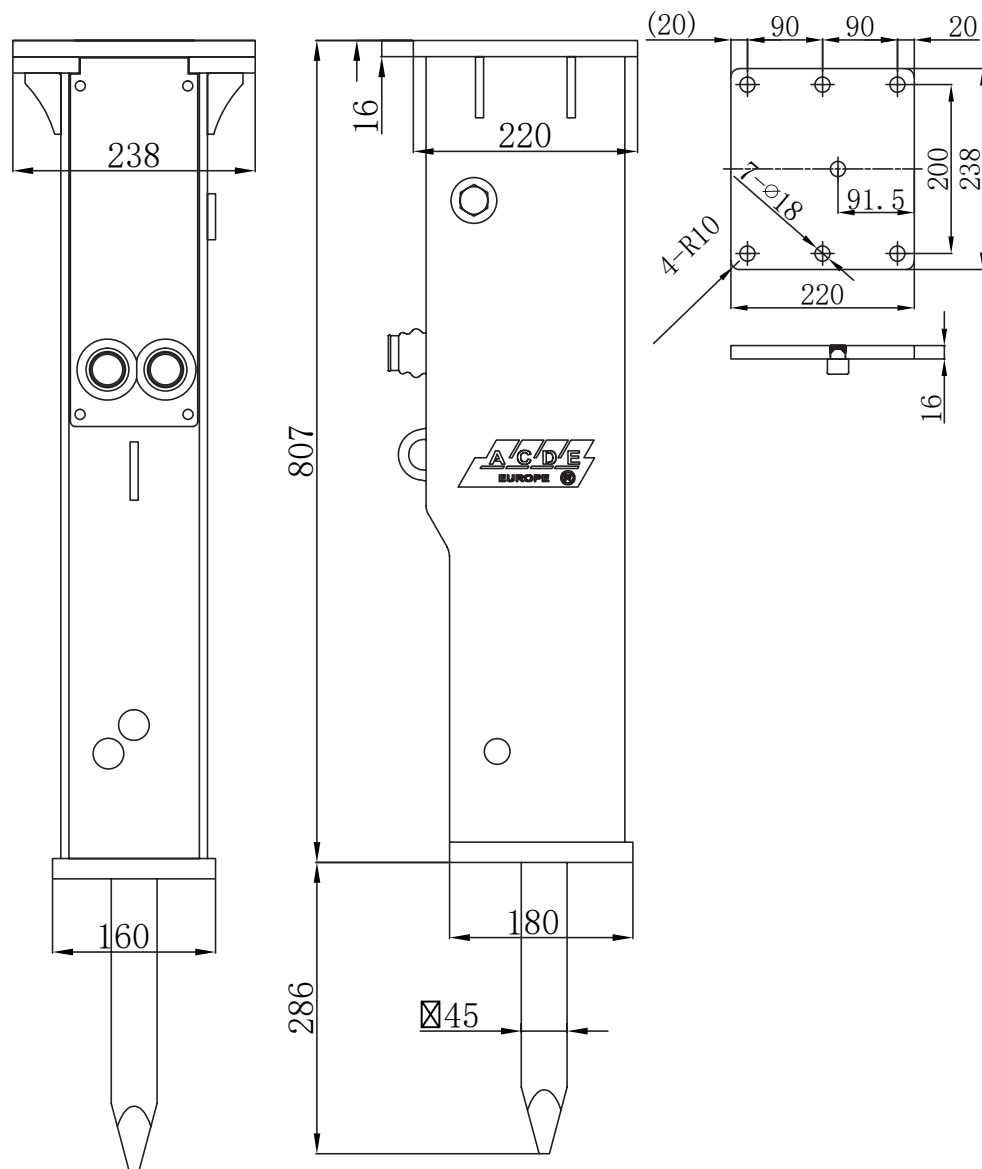

ACCESSOIRES

IMAGE	MODELL/TYPE	DESCRIPTION
	ACDE	N2 filling device
	ACDE	Hammer paste cartridge
	ACDE	Grease gun + cartridge

BRACKETS

IMAGE	MODELL	DESCRIPTION
	ACDE	CW 05
	ACDE	MS 01
	ACDE	MS 03

