



## ADVANCED CONSTRUCTION & DEMOLITION EQUIPMENT

**ASB155 PARTSLIST 06/2019**

 **Hydraulische Hamer**

 **Hydrauliek Hammer**

 **Hydraulic Breaker**

 **Marteaux Hydrauliques**



**ACDE EUROPE B.V.**  
Frans Halsstraat 5  
6901DC Zevenaar  
The Netherlands

**Phone** +31 316 26 72 91  
**E-mail** [info@acde-europe.com](mailto:info@acde-europe.com)  
**Web** [www.acde-europe.com](http://www.acde-europe.com)  
**Mobile** +31 6 53 150 283

**COPYRIGHT©, ACDE EUROPE BV,  
ALL RIGHTS RESERVED**

# ASB155 BODY

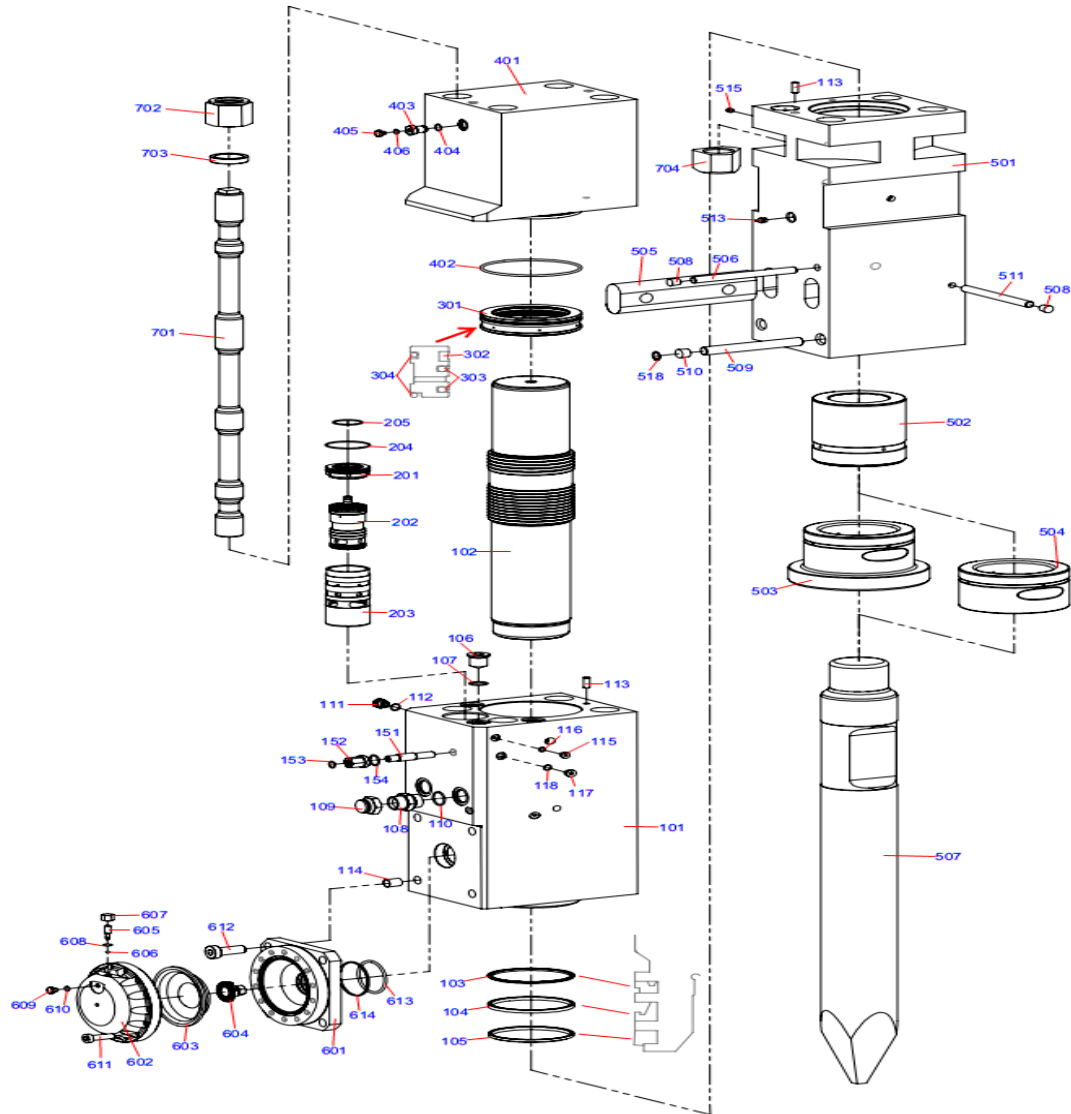

# ASB155 PART LIST

PART NO.	PART NAME	SPECIFICATION	NUM
<b>155-100</b>	<b>CYLINDER ASSEMBLY</b>		<b>1</b>
155-101	CYLINDER	288*383*628	1
155-102	PISTON	Φ157*Φ173.5*Φ160*832	1
155-103	BUFFER RING	HBV 160*175.5*6	1
155-104	U-PACKING	IUIS 160*175*9	1
155-105	DUST SEAL	LBI 160*173*7*9.5	1
155-106	CYLINDER PLUG	4HN-36	3
155-107	CYLINDER PLUG O-RING	1BP-32	3
155-108	IN/OUT ADAPTER	1BG-20	2
155-109	IN/OUT ADAPTER COVER	9B-20	2
155-110	IN/OUT ADAPTER O-RING	1BP-38	2
155-111	EXHAUST VALVE	G 1/2'	1
155-112	EXHAUST VALVE O-RING	1BP-18	1
155-113	GUIDE PIN	Φ12.5*30	2
155-114	BOLT	ST24*3*10	4
155-115	PLUG	4GN-04	6
155-116	O-RING	1BP-11	6
155-117	PLUG	4GN-06	1
155-118	O-RING	1BP-14	1
<b>155-150</b>	<b>VALVE ADJUSTER ASSEMBLY</b>		<b>1</b>
155-151	FRONT VALVE	M22*P1.5*96	1
155-152	FRONT VALVE NUT	M22*P1.5*33	1
155-153	FRONT VALVE O-RING	1BP-18	1
155-154	FRONT VALVE O-RING	1BP-29	1
<b>155-200</b>	<b>VALVE ASSEMBLY</b>		<b>1</b>
155-201	VALVE COVER	φ90*31	1
155-202	VALVE	φ16*φ75*φ71*135	1
155-203	VALVE SLEEVE	φ90*179	1
155-204	O-RING	1BG-85	1
155-205	O-RING	1BG-55	1

## ASB155 PARTS LIST

PART NO.	PART NAME	SPECIFICATION	NUM
<b>155-300</b>	<b>PISTON BUSH ASSEMBLY</b>		<b>1</b>
155-301	PISTON BUSH	Φ205*53	1
155-302	GAS SEAL	IKH-157*169.8*10	1
155-303	STEP SEAL	SPNS-157	2
155-304	O-RING	1BG-195	2
<b>155-400</b>	<b>BACK HEAD ASSEMBLY</b>		<b>1</b>
155-401	BACK HEAD	288*383*375	1
155-402	O-RING	1BG-195	1
155-403	GAS CHARGING VALVE	G 1/2'	1
155-404	O-RING	1BP-18	1
155-405	GAS CHARGING VALVE COVER	M10*P1.0	1
155-406	O-RING	1BP-12	1
<b>155-500</b>	<b>FRONT HEAD ASSEMBLY</b>		<b>1</b>
155-501	FRONT HEAD	288*326*765	1
155-502	THRUST BUSH	φ155*φ189*205	1
155-503	CHISEL BUSH	φ155*φ224*170	1
155-504	(SILENCED CHISEL BUSH)		1
155-505	CHISEL PIN	96*52*326	2
155-506	BUSHING PIN	φ20x245	1
155-507	CHISEL	φ155*1300	2
155-508	RUBBER PLUG1	φ20x21	2
155-509	CHISEL BUSH PIN	φ26x232	2
155-510	RUBBER PLUG2	φ26x20.5	2
155-511	LOCKING PIN	φ20x245	1
155-513	GREASE NIPPLE	G 1/4'	1
155-515	PROCESS PLUG	M12X1.75X10	1
155-518	SNAP RING	Φ26	2

## ASB155 PARTS LIST

PART NO.	PART NAME	SPECIFICATION	NUM
<b>155-600</b>	<b>ACCUMULATOR ASSEMBLY</b>		<b>1</b>
155-601	ACCUMULATOR BOTTOM	257*257*79	1
155-602	ACCUMULATOR COVER	Φ253*74	1
155-603	DIAPHRAGM	φ192*40	1
155-604	INNER VALVE ASSEMBLY	Φ65*8/Φ60*7/10	1
155-605	GAS CHARGING ADJUSTER	M12*P1.25	1
155-606	GAS CHARGING O-RING	1BP-5	1
155-607	GAS CHARGING CAP	M12*P1.25	1
155-608	GAS CHARGING CAP O-RING	1BP-14	1
155-609	ACC'COVER CAP	M10*P1.0	1
155-610	ACC'COVER CAP O-RING	1BP-12	1
155-611	INNER COVER HEX.SOCKET BOLT	M16*P2.0*40	14
155-612	INNER BOTTOM HEX.SOCKET BOLT	M24*P3.0*60	4
155-613	O-RING	1BP-95	1
155-614	WHITE RING	4BP-95	1
<b>155-700</b>	<b>THROUGH BOLT ASSEMBLY</b>		<b>1</b>
155-701	THROUGH BOLT	RD56XP4.233X1148	4
155-702	SCREW NUT(UPPER)	RD56XP4.233X65	4
155-703	WASHER	φ75*φ57*15	4
155-704	SCREW NUT(LOWER)	RD56XP4.233X55	4

# ASB155 HOUSING

# ASB155 PARTS LIST HOUSING

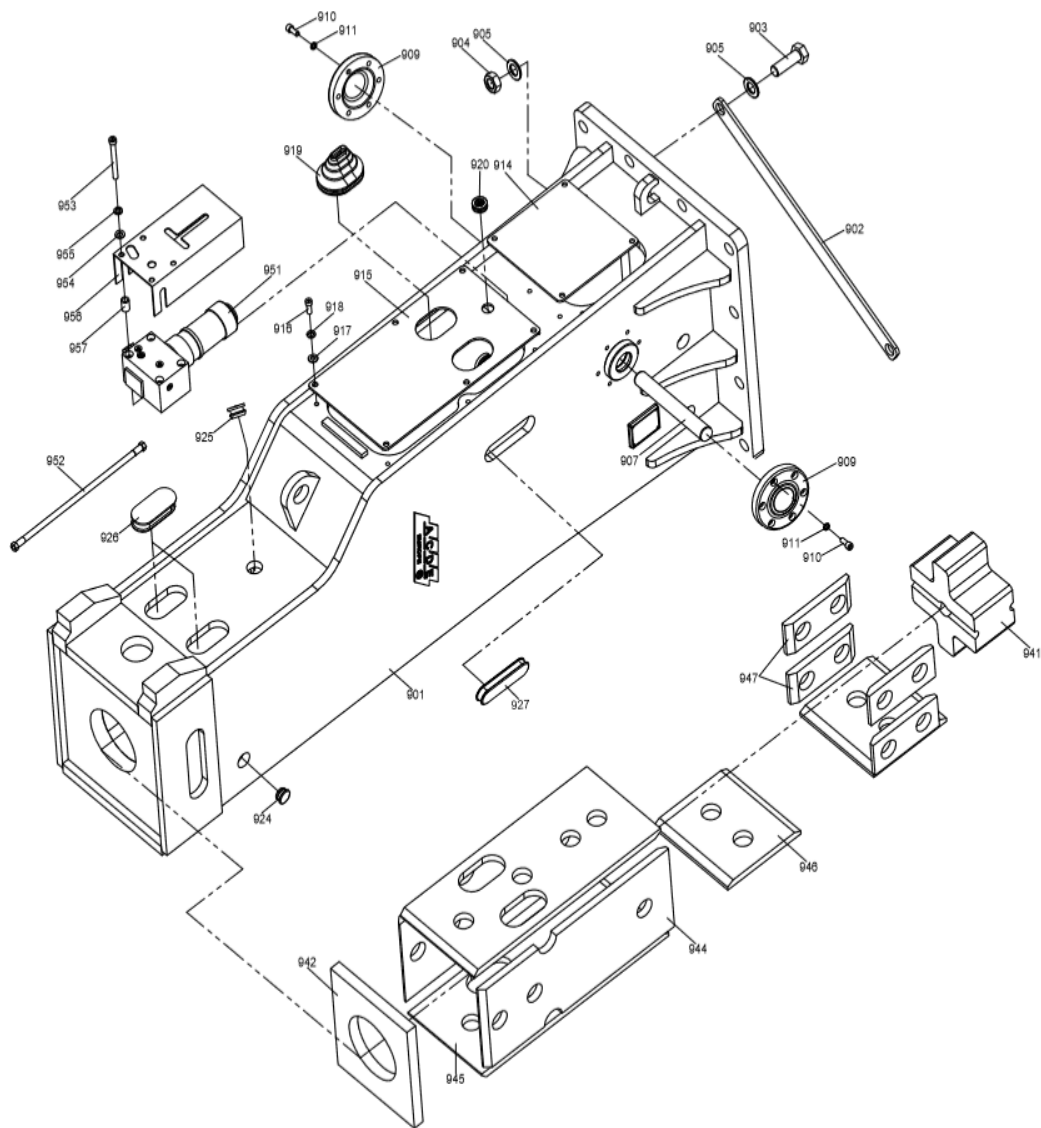

PART NO.	MODEL	SPECIFICATION	QUANTITY	
ASB-155-900	FRAME ASS'Y			
ASB-155-901	FRAME (BOX TYPE)	650×820×1949	1	
ASB-155-902	IRON BAR	686×50×10	1	
ASB-155-903	M/C HEX BOLT	M30×110	12	
ASB-155-904	M/C HEX NUT	M30	12	
ASB-155-905	NORD-LOCK	30	24	
ASB-155-907	HOUSING BOLT	φ 50×405	1	
ASB-155-909	BOLT CLAMP	φ 176×25	2	
ASB-155-910	HEX BOLT	M12×30	12	
ASB-155-911	WASHER	12	12	
ASB-155-914	COVER PLATE-A	345×252×6	1	
ASB-155-915	COVER PLATE-B	289×294×6	1	
ASB-155-916	HEX BOLT	M12×30	10	
ASB-155-917	NORD-LOCK	12	10	
ASB-155-918	NORD-LOCK	12	10	
ASB-155-919	OIL HOSE COVER	G1	2	
ASB-155-920	GREASE OIL HOSE COVER	φ 30	1	
ASB-155-924	RUBBER PLUG		6	
ASB-155-925	RUBBER PLUG		1	
ASB-155-926	RUBBER PLUG		4	
ASB-155-927	RUBBER PLUG		2	
ASB-155-940	BUFFER PLATE ASS'			
ASB-155-941	TOP BUFFER	307×261×153	1	
ASB-155-942	SIDE DAMPER-A	326×288×30	1	
ASB-155-944	SIDE DAMPER-B	640×264×20	2	
ASB-155-945	SIDE DAMPER-C	640×278×20	2	
ASB-155-946	SIDE DAMPER-D	278×250×20	2	
ASB-155-947	SIDE DAMPER-E	220×100×20	4	
ASB-155-950	AUTOLUB GREASE TOOL			
ASB-155-951	AUTOLUB GREASE	Large size	1	
ASB-155-952	GREASE OIL HOSE	G1/4	1	
ASB-155-953	M/C HEX BOLT	M12×130	4	
ASB-155-954	WASHER	12	4	
ASB-155-955	SPRING WASHER	12	4	
ASB-155-956	AUTOLUB GREASE COVER	Large size	1	
ASB-155-957	AUTOLUB GREASE OIL HOSE	φ 20× φ 13×30	4	

# ASB155 HOUSING MEASUREMENT

# ACCESOIRES

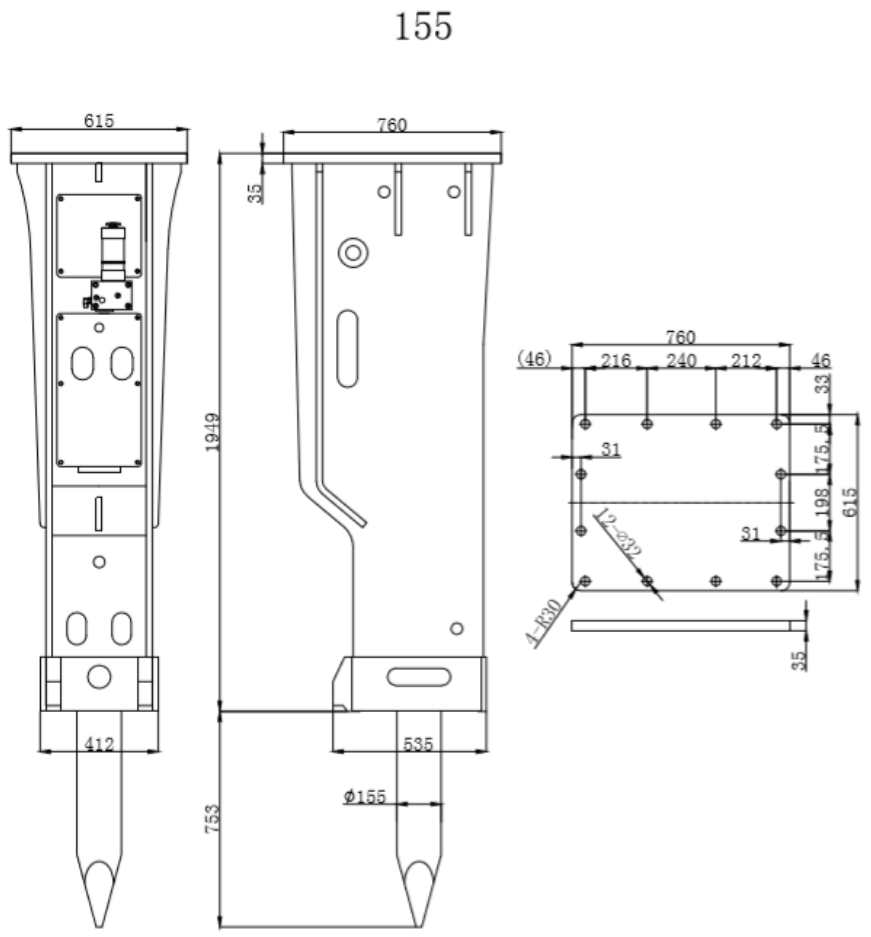





IMAGE	MODELL /TYPE	DESCRIPTION
	ACDE	N2 Filling Device
	ACDE	Hammer paste cartridge
	ACDE	Grease gun + cartridge

